

# ***EMMO MONSTER S***

**OWNER'S MANUAL**



# Preface

## **An Important Message From EMMO**

Thank you for choosing EMMO. Congratulations on your purchase of a new Monster S.

This document is intended as a short introduction to your new e-bike. It contains essential safety, performance and service information. Please read and understand this manual fully before assembling and riding your bike. Be sure to watch the official Emmo Monster S assembly video available at <https://emmo.ca/pages/e-bike-assembly-guide>.

Additional information about your bike can be found on our website at [www.emmo.ca](http://www.emmo.ca).

Be sure to check all hardware for correct torque during assembly.

## **Illustrations**

Illustrations shown in this document may differ in detail from the exact configuration on your particular e-bike model. The illustrations are a general reference for instruction and description purposes only.

## **Service & Support**

If you have questions after reading this manual and watching the assembly video, please feel free to contact us.

**E-mail:** [service@emmo.ca](mailto:service@emmo.ca)

**Toll Free:** 1-888-217-1217

**Find Emmo dealers near you:** <https://emmo.ca/pages/locations>

# Content

<b>About This Manual</b> .....	<b>5</b>
<b>About EMMO</b> .....	<b>6</b>
<b>Rules and Regulations</b> .....	<b>7</b>
<b>Safety Disclaimer</b> .....	<b>11</b>
<b>Description</b> .....	<b>15</b>
Schematic Diagram .....	15
Side View .....	15
Handlebar Attachments .....	16
<b>Operation Guide</b> .....	<b>17</b>
Switch .....	17
Right Switch .....	17
Left Switch .....	18
Throttle .....	19
Lights & Signals .....	20
Speedometer .....	23

<b>Audio System</b> .....	<b>24</b>
<b>Kickstand &amp; Centre Stand</b> .....	<b>26</b>
Side Kickstand.....	26
Centre Stand .....	27
<b>Rear View Mirrors</b> .....	<b>29</b>
<b>How to Turn on the Bike</b> .....	<b>31</b>
Key Ignition .....	31
Remote .....	34
<b>How to Lock the Steering</b> .....	<b>35</b>
<b>Circuit Breaker</b> .....	<b>38</b>
<b>How to Charge</b> .....	<b>43</b>
Lead Acid Charger.....	43
Lithium Charger.....	49
Charging Precautions .....	56
Battery Safety Precautions .....	58
Disposal.....	59

Storage & Maintenance .....	60
<b>Troubleshooting .....</b>	<b>61</b>
<b>Recommended Torque Values .....</b>	<b>63</b>
<b>Tools and Torque Values .....</b>	<b>65</b>
<b>Riding Guide .....</b>	<b>66</b>
<b>Warranty Policy .....</b>	<b>67</b>
<b>Leave Us a Review .....</b>	<b>70</b>
<b>E-Bike Registration .....</b>	<b>71</b>
<b>Contact Us.....</b>	<b>72</b>

# About This Manual

This document is intended as a short introduction to your new e-bike. It contains important safety, performance and service information. Read and understand it along with the information provided during the on-delivery instructions before using the product. Pay special attention to the safety messages as shown here, and keep the manual handy for future reference.



**WARNING:** Warning about a situation that can cause death, serious physical injury and or heavy material damage if one does not obey the safety instructions.



**DANGER:** Danger statement indicates a hazardous situation that, if not avoided, has a very high risk of death, serious injury, or property damage.



**CAUTION:** Caution statement indicates a hazardous situation that, if not avoided, could result in minor or moderate injury or property damage.



**NOTICE:** Notice is important information that can help you avoid bike/property damage or extend the life of parts and the bike.

# About EMMO

Emmo is a proud Canadian company based in Toronto, Ontario. As the leading brand of electric bikes, Emmo has provided over 500,000 people with environmentally-friendly transportation throughout North America. We believe that electric mobility for everyone is a big step in moving towards a zero-emission future.

Since 2009, Emmo has offered a large selection of electric mobility options for commuting and recreation. With our diversity of products, we create high-quality options to accommodate everyone's needs with an emphasis on reducing their carbon footprint. The past decade has proven that Emmo e-bikes are not only a sustainable method of transportation, but that they also push the limits of conventional bikes –to take you further, with less effort and more fun.

Driven by our vision of inspiring more people to lead a greener lifestyle, Emmo strives to give our riders' the best experience possible. Our in-house research and development spans two continents. Our e-bikes are designed in North America and undergo rigorous testing at our state-of-the-art facilities. Throughout this process, every facet of this complex supply chain is vigorously scrutinized to ensure the end product arrives in flawless condition at our four distribution centers in North America. We continue to be at the forefront of the e-bike industry. With over 100 retailers, Emmo is never too far away.

For over 13 years, our strong commitment to design and innovation has resulted in every Emmo product encompassing the latest technology. Our e-bikes exclusively use programmable sine-wave BLDC controllers, allowing higher performance, longer range and enhanced reliability in all conditions. Backed by our comprehensive warranty, we ensure riders are confident in the purchase of their Emmo.

Emmo believes that a greener future is not only possible, it's necessary, and we want to do our part to build greener communities by making e-bikes more accessible.

# Rules and Regulations

According to **Canada's Motor Vehicle Safety Regulations ( MVSR )**. A qualified e-bike (defined as Power Assist Bicycle) must meet the following requirements:

- The e-bike must have operational pedals
- Upper wattage limit for the motor is 500W
- Maximum speed of an e-bike is 32km/h.

Other requirements include a permanently affixed compliance label from the manufacturer stating that the vehicle is a power-assisted bicycle under statutory requirements in force at the time of manufacture. Currently, there is no license, no insurance, and no vehicle registration required to operate a qualified e-bike according to federal legislation. E-Bike riders share the same rights and responsibilities as other road users.

However, provinces and local municipalities have the power to restrict the use of e-bikes. Most provinces require the rider to wear a helmet. Some provinces have special requirements with regard to the age limit to operate an e-bike, the type of helmet required, even the number of wheels and wheel size. In Ontario, typically, e-bikes are generally treated the same as regular bicycles. According to the Ministry of Transportation of Ontario (MTO), the age limit to operate an e-bike is 16 years old and above; the maximum weight of the bike is 120 kilograms (265 pounds); the bike must have a brake distance of less than 9 meters; Any modifications made to the bike's motor to create speeds greater than 32km/h are prohibited.

The rules and regulations are subject to changes in different provinces and municipalities. Please check your municipal bylaw and see where you stand.

# Rules and Regulations

## Useful links:

E-Bike Regulations in Ontario:

<https://www.ontario.ca/page/riding-e-bike>

E-Bike Regulations in British Columbia:

[https://www.bclaws.gov.bc.ca/civix/document/id/complete/statreg/151\\_2002](https://www.bclaws.gov.bc.ca/civix/document/id/complete/statreg/151_2002)

E-Bike Regulations in Alberta:

<http://www.transportation.alberta.ca/content/doctype45/production/mopedpowerbikes.pdf>

E-Bike Regulations in Manitoba:

<https://web2.gov.mb.ca/laws/statutes/ccsm/h060e.php>

E-Bike Regulations in Saskatchewan:

[https://www.sgi.sk.ca/motorcycle/-/knowledge\\_base/motorcycle-handbook/power-assisted-bicycles1](https://www.sgi.sk.ca/motorcycle/-/knowledge_base/motorcycle-handbook/power-assisted-bicycles1)

E-Bike Regulations in Quebec:

<https://saaq.gouv.qc.ca/en/road-safety/modes-transportation/electric-bike>

E-Bike Regulations in New Brunswick:

[https://www2.gnb.ca/content/gnb/en/services/services\\_renderer.200814.Motor\\_Vehicle\\_Registration.html](https://www2.gnb.ca/content/gnb/en/services/services_renderer.200814.Motor_Vehicle_Registration.html)

E-Bike Regulations in Nova Scotia:

<https://novascotia.ca/just/regulations/regs/mv18786.htm>

E-Bike Regulations in Prince Edward Island:

<https://www.princeedwardisland.ca/en/information/transportation-and-infrastructure/power-assisted-bicycles>

### **Know and obey all relevant local laws**

It is your responsibility to research and understand relevant laws where you ride your bike. Such laws may cover required helmets and safety gear, required lights and reflectors, required hand signals, where you can legally ride a bike (bikes and ebikes may have different restrictions), how fast you can go, what (if any) cargo or passengers you can carry, rider age, and more. Before using public transportation—buses, trains, etc.—to transport your e-bike, check with the relevant transportation authority for any rules governing weight limits, tire widths, lithium-ion batteries, or any other rules that might pertain to e-bikes. When you ride on the road, assume you must, at minimum, follow all of the rules that cars must follow. For additional information regarding traffic and vehicle laws, contact the road traffic authority in your area.

The product(s) comply with federal regulations for this product category in Canada and with applicable provincial regulations in the region of sale at the time of purchase. In jurisdictions where the product(s) may NOT be compliant, the buyer acknowledges this possibility and accepts full responsibility for their use. The buyer is solely responsible for understanding and complying with all applicable laws, regulations, and bylaws related to the operation and use of the product(s) in their local area. If the product(s) are capable of going faster than the applicable legal speed limit, the

seller is NOT responsible for the speed at which the buyer operates the product(s). Any future changes to legislation or regulatory classification that affect where or how the product(s) may be used are outside the control of the seller and shall NOT constitute valid grounds for return, refund, or compensation. Such changes do NOT imply any defect or misrepresentation of the product(s) at the time of sale.

# Safety Disclaimer

This manual contains important safety, performance, and service information. Read and understand it along with the information provided during the on-delivery instructions before using the product, and keep it for reference. Ensure that you comprehend all instructions and safety NOTes/warnings.

**Definition:** In this manual, the term “Vehicle” refers collectively to any bike, ebike, etrike, or similar vehicle sold or authorized by EMMO.

## General Responsibility

- By choosing to ride a Vehicle, you assume full responsibility for all risks, including falls, collisions, equipment failure, and road or traffic hazards.
- Riders are responsible for following local laws and bylaws, practicing safe riding, and maintaining the Vehicle properly.
- Safe use depends on responsible riding, regular inspections, and timely replacement of worn components.



### **WARNING: Fit & Capability**

- Ensure the Vehicle fits you properly before riding; incorrect sizing may cause loss of control.
- Riders must have sufficient physical condition, reaction time, and mental capability to handle traffic and emergencies. If you have medical conditions (including impairments or seizure disorders), consult your physician before riding.
- Before the first ride, practice braking and throttle control in a safe environment.

- If riding at night, familiarize yourself with the lights and signals and ensure they function properly.



## **WARNING: Installation & Maintenance**

- Improper installation, compatibility issues, or poor maintenance can cause serious injury or death.
- Secure all hardware (handlebar, grips, seat, pedals, etc.) before each ride.
- Have the Vehicle inspected by an authorized technician at least once every **6 months**.
- It is your full responsibility to ensure the Vehicle is in good working order at all times. Perform a pre-ride safety check **before every ride** (brakes, throttle, sensors, lights, and other key components).



## **WARNING: Battery & Charger Safety**

- The charger should only be used **indoors** in a cool, dry, ventilated area. Always position the charger on a **non-flammable surface** (e.g., concrete or brick), as it may generate heat during peak charging cycles.
- You must use a **dedicated 110V outlet** to charge your battery.
- Never cover the charger during charging or leave it unattended.
- Keep the battery and charger away from children, pets, water, and open flame.
- DO NOT submerge or allow the charger to be submerged in water or any liquid.
- **DO NOT** use the charger or battery if **any part of the cord, connector, or housing is frayed, cracked, exposed, or otherwise damaged**. Using damaged charging equipment or battery connectors can lead to malfunction, fire, or serious injury.

- Do NOT drop, strike, or expose them to shocks.
- Use only the charger supplied with the product or approved by EMMO.
- Disconnect promptly once fully charged. Do NOT charge for more than **12 hours**, whether the battery is full or not.
- If the battery is stored, check it at least **once a month**. If necessary, use the original charger to recharge the battery to about **75%**. Failure to perform regular checks or charging may result in malfunction or safety hazards.
- Disconnect immediately if there is a strange smell, smoke, or overheating.
- In the unlikely case of battery fire: **never use water**. Use sand to cover the fire and call emergency services.
- **Battery & Charger Rated Life Expectancy:** Lead-Acid Battery: 2 years (500 cycles); Lithium-Ion Battery: 4 years (1000 cycles); Charger: 4 years. All component lifespans assume normal use and proper maintenance. **Annual inspection & safety testing by an authorized technician are required to ensure safety.** Components that have exceeded their rated service life—or no longer provide expected performance—should be replaced to ensure safety and reliability. While proper care may extend usable life, this can NOT be guaranteed.



## **WARNING: Modifications & Non-Original Components**

- Do NOT use the Vehicle with trailers, stands, racks, or accessories that are not approved by EMMO. The use of non-original components or spare parts can jeopardize the safety of your Vehicle, void your warranty, and, in some cases, cause your Vehicle to not conform with applicable laws.
- Any unauthorized modifications (to the electrical system, controller, battery, or structural components) may compromise safety. **Such modifications void the warranty and are performed at the rider's sole risk.**



## **WARNING: Extreme Riding**

- Vehicles and components are NOT designed for extreme use such as jumps, stunts, or riding beyond your ability.
- Extreme riding may cause component failure, severe injury, or death.

### **Final Note:**

- Always ride responsibly, maintain the Vehicle regularly, and replace components when necessary.
- The rider assumes all risks associated with operating this Vehicle.
- For questions or concerns, contact your authorized EMMO dealer or EMMO Customer Support.

# Description

## 1. Schematic Diagram

### a. Side View

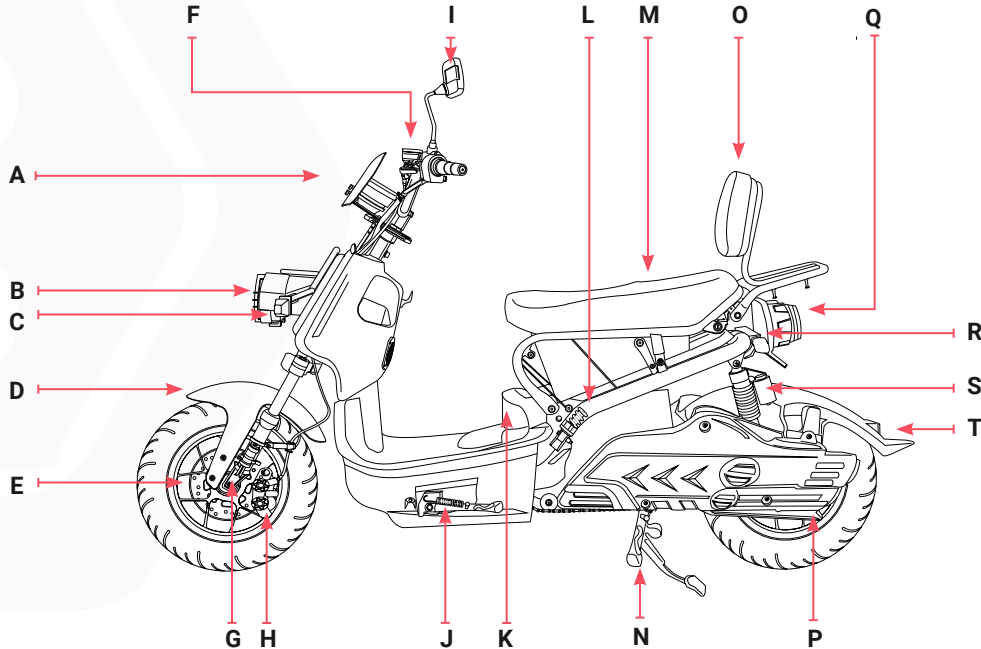

<b>A</b>	Windshield
<b>B</b>	Headlight
<b>C</b>	Front Turning Signals
<b>D</b>	Front Fender
<b>E</b>	Front Wheel
<b>F</b>	Handlebar
<b>G</b>	Front Air Shocks
<b>H</b>	Front Brake Caliper
<b>I</b>	Mirrors
<b>J</b>	Kickstand
<b>K</b>	Charging Port
<b>L</b>	Passenger Footpeg
<b>M</b>	Seat Cushion
<b>N</b>	Centre Stand
<b>O</b>	Back rest
<b>P</b>	Chan Cover
<b>Q</b>	Tail Light
<b>R</b>	Rear Turning Signals
<b>S</b>	Rear Air Shocks
<b>T</b>	Rear Fender

# Description

## 1. Schematic Diagram

### b. Handlebar Attachments

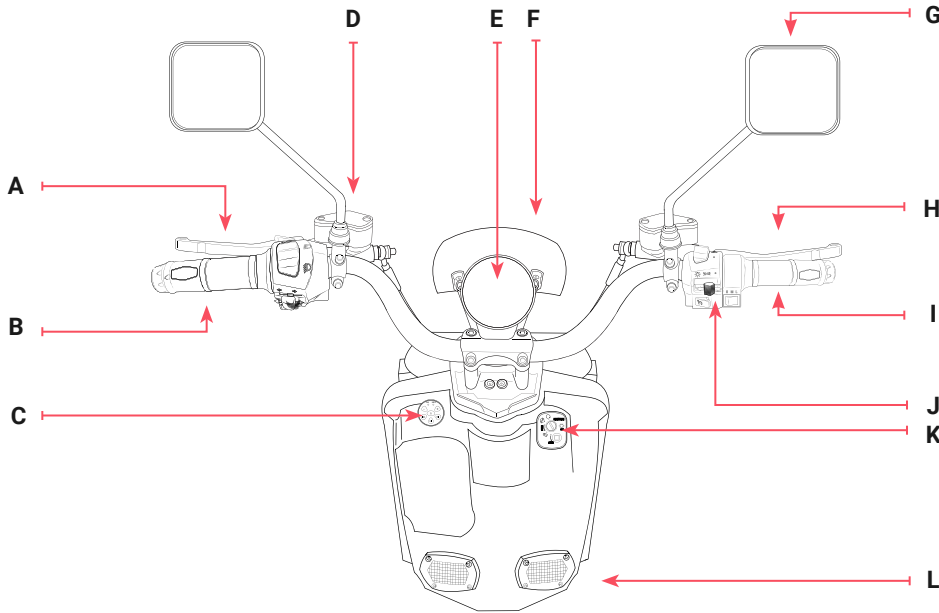

<b>A</b>	Left Braker Lever
<b>B</b>	Left Grip
<b>C</b>	Audio Control Pad
<b>D</b>	Brake Fluid Tank
<b>E</b>	Speedometer
<b>F</b>	Windshield
<b>G</b>	Rear View Mirrors
<b>H</b>	Right Brake Level
<b>I</b>	Throttle
<b>J</b>	Switching Housing
<b>K</b>	Iginition
<b>L</b>	Speakers





# Operation Guide

## 2. Switch

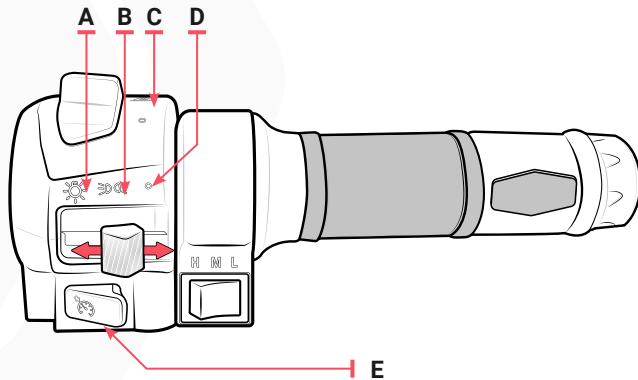
### a. Right Switch

The switch housing on the handlebar hold these switches that control the lights, signals, horn and etc..







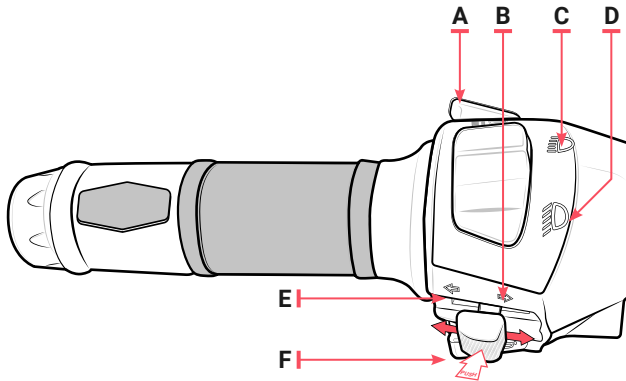

A		Headlight + Tail light	Slide the switch to turn on the headlight and tail light.
B		Tail Light	Slide the switch to turn on the tail light.
C		Emergency Harzard Lights	Press the button to turn on all turning signal lights.
D		Off	Slide the switch to turn off the light.
E		Cruise Control	Press the button to activate the cruise control. To cancel the cruise function, press the button again or apply the brake.

# Operation Guide

## 2. Switch

### b. Left Switch



A		High Beam Flasher	Press the button will flash the high beam.
B		Right Turning Signal	Slide the switch to the right will turn on the right side turning signals. (Push the switch lever in to cancel the turning signal).
C		High Beam Light	Press it down will turn the high beam on.
D		Low Beam Light	Press it down will turn the low beam on.
E		Left Turning Signal	Slide the switch to the left will turn on the left side turning signals.(Push the switch lever in to cancel the turning signal).
F		Horn	Press the button to sound the horn.

# Operation Guide

## 3. Throttle

The throttle controls the speed of the e-bike. As shown below, twist the throttle towards you to operate. With the help of the speed mode switch, you can also change the speed setting.

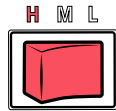
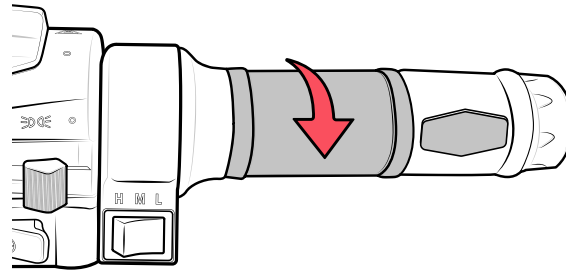

**HIGH SPEED**

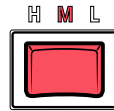

**MEDIUM SPEED**

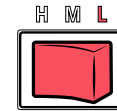

**LOW SPEED**



**WARNING: DO NOT** turn the throttle if you are not ready to ride.

# Operation Guide

## 4. Lights & Signals

The headlight assembly has multiple operation modes - high beam, low beam and fog light, to accommodate your needs under different conditions.

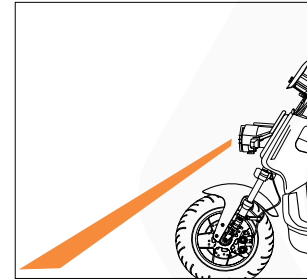
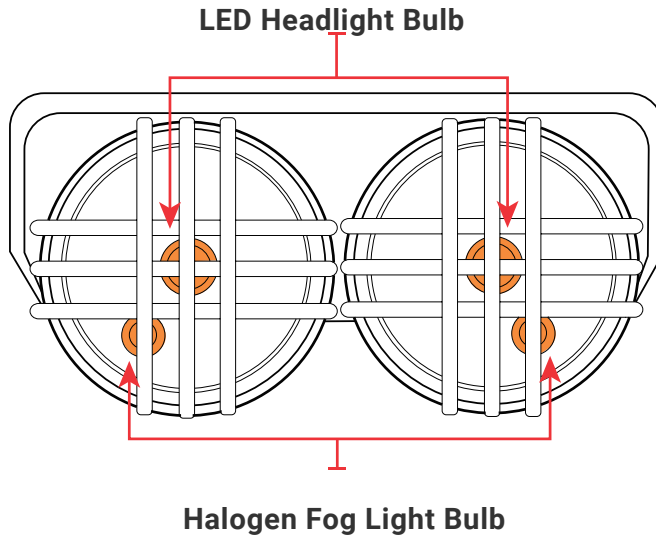

Headlight - Low Beam

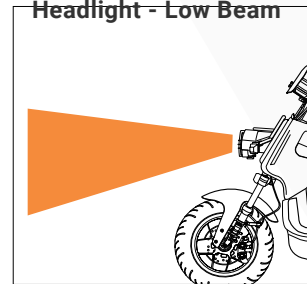

Headlight - High Beam

# Operation Guide

## 4. Lights & Signals

Tail light and brake light play an important role in signaling people behind. With the help of the turning signal lights, it is also easier for other road users to anticipate your intended route.

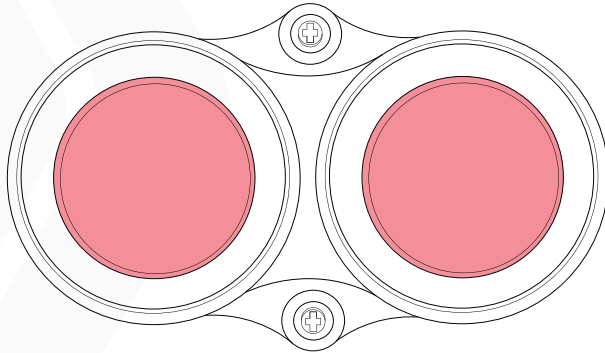

**Tail Light On**

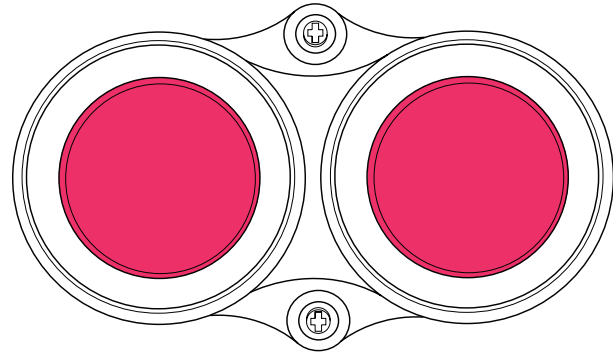

**Brake Light On**

**!** **NOTICE:** The Tail lights become brighter when the brake is applied.

# Operation Guide

## 4. Lights & Signals

Daytime running light is integrated into the signal light assembly. When the signal light is on, the daytime running light will be switched off automatically.

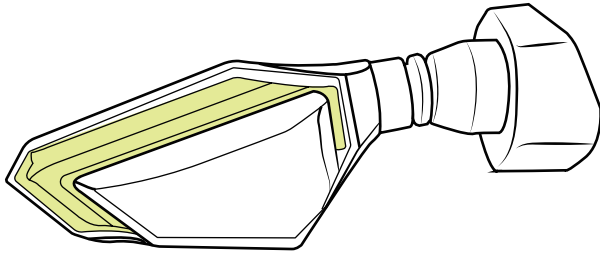

**Daytime Running Light (Solid White)**

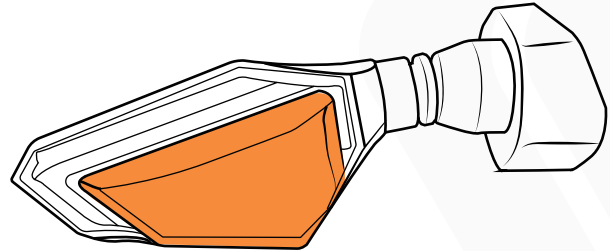

**Dynamic Turning Signal Light (Amber)**

# Operation Guide

## 5. Speedometer

The Speedometer let you know the working status of the bike. It provides information including the current speed, total travel distance, battery strength, and speed mode (3=high speed mode, 2=medium speed mode, 1=low speed mode).

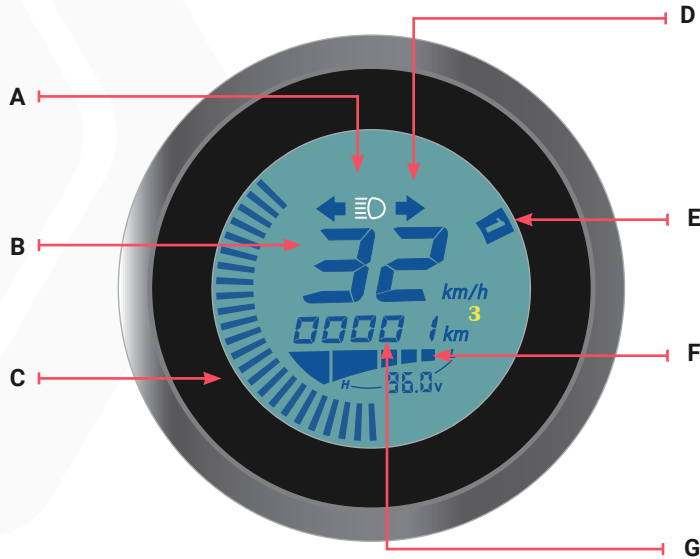

**A** High Beam Indicator

**B** Current Speed

**C** Power Output Indicator

**D** Turning Signal Indicator

**E** Current Speed Mode

**F** Battery Strength Indicator

**G** Odometer

# Operation Guide

## 6. Audio System

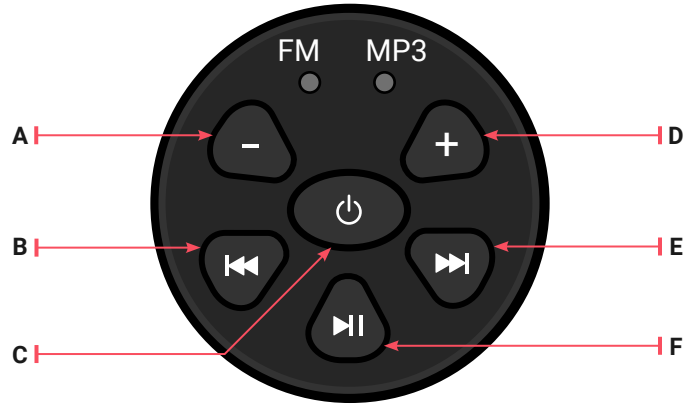

# Operation Guide

## 6. Audio System

<b>A</b>	Volume Down	Turn the volume down.
<b>B</b>	Previous	<b>MP3</b> - Press the button once to play the previous song in the list. <b>FM radio</b> - Press the button once to switch to previous channel in the list.
<b>C</b>	Power / Mode Switch	Press once to turn on the radio system. 1. The <b>MP3</b> mode is set by default. You can pair your bluetooth device with the built-in <b>MP3</b> player (named <b>Electric bike</b> ). Press the button again to switch to <b>FM radio</b> mode. Press the button again to turn off the radio system.
<b>D</b>	Volume Up	Turn the volume up.
<b>E</b>	Next	<b>MP3</b> - Press the button once to play the next song in the list. <b>FM radio</b> - Press the button once to switch to next channel in the list. Hold the button to search for available channels (initialization).
<b>F</b>	Play / Pause	<b>MP3</b> - Press the button once to pause. Press again to continue to play. <b>FM radio</b> - Hold the button for 5 seconds to search for available channels. Once finished the system will stop at the first channel.

# Operation Guide

## 7. Kickstand & Centre Stand

### a. Side Kickstand

The bike is equipped with a side kickstand and a centre stand. The side kickstand is easier to use. By contrast, to use the centre stand requires some techniques and practice, but the bike is more stable on the centre stand.

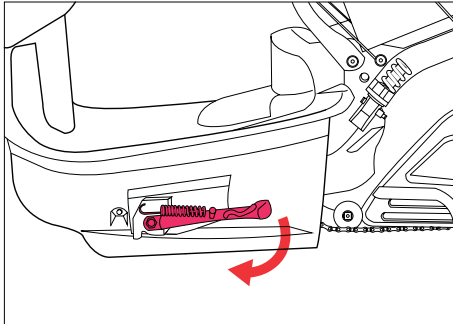

**Kick the side stand down and gently lean the bike on the side kickstand**

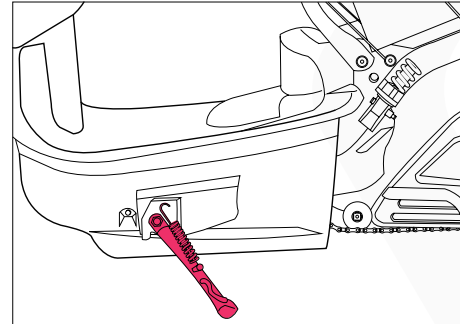

**Make sure it is stable before you leave your bike.**

# Operation Guide

## 7. Kickstand & Centre Stand

### b. Centre Stand

Stand on the left side of the bike. The centre stand is under the swing arm cover.

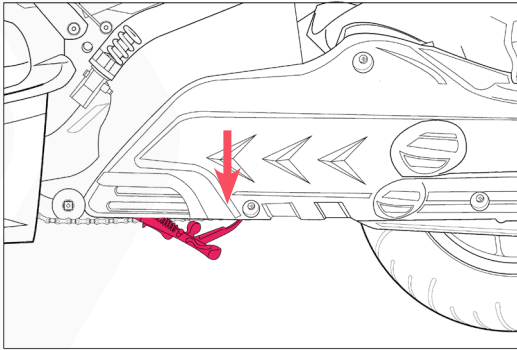

Step on the centre stand peg firmly with your right foot.

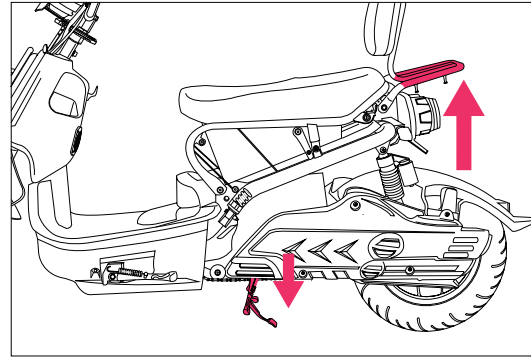

While keeping your balance, step down on the peg firmly and lift the rear rack up.

# Operation Guide

## 7. Kickstand & Centre Stand

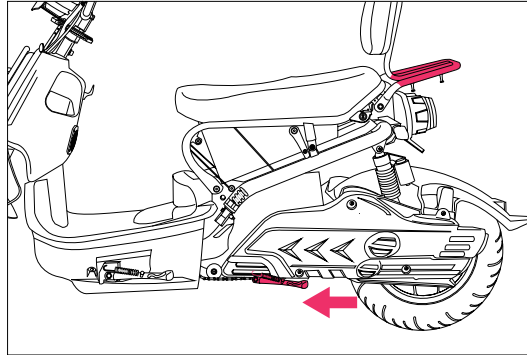

To get the bike off the centre stand, put your right foot in front of the centre stand and gently push the bike forward.



**WARNING:** Both side kickstand and centre stand should be kicked up before you ride the bike. Be careful when putting the bike on the centre stand. If you find it difficult to use the centre stand, visit your EMMO dealer for a more detailed demonstration on how to use the centre stand.

# Operation Guide

## 8. Rear view mirrors

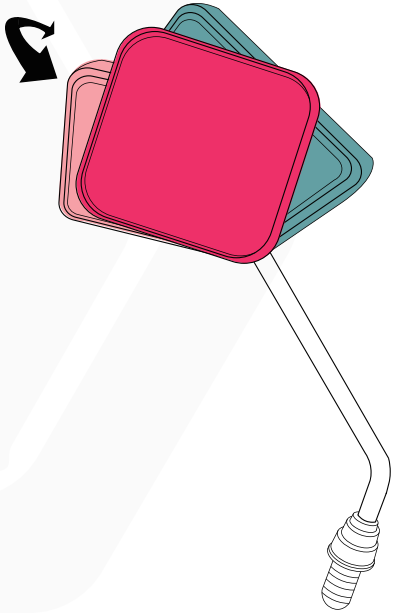

Rear view mirrors make it safer for you to check the traffic condition behind you. Please make sure the rear view mirrors are adjusted and secured properly. Check the rear view mirror and your blind spots before you make a turn or overtake other vehicles.

- The mirror can be tilted up and down for approximately 15 degrees from the centreline.
- The mirror can also be rotated on the holding pole.

# Operation Guide

## 8. Rear view mirrors

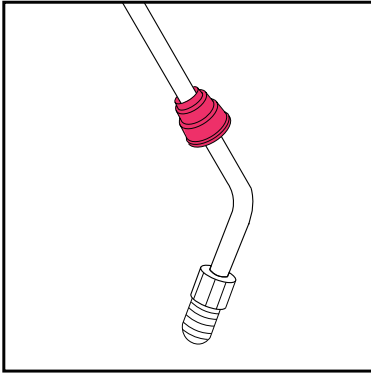

The nut is covered by the plastic cap.  
Lift up the cap to expose the nut.

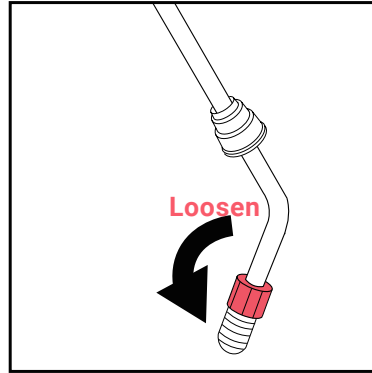

Use the wrench and follow the direction indicated to loosen the nut slightly.

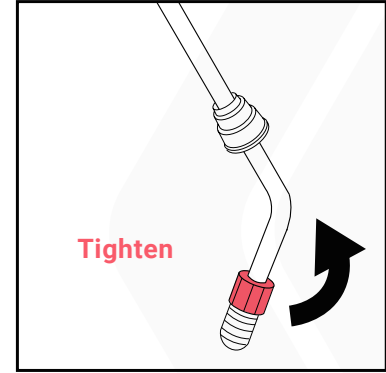

Adjust the mirror to a preferred position and tighten the nut as shown.



### **WARNING:**

- **DO NOT** adjust the mirrors while you are riding the bike.
- Be careful when you tightened the nut to avoid damage to the threads and the mirror holders.

# Operation Guide

## 9. How to turn on the bike

### a. Key Ignition

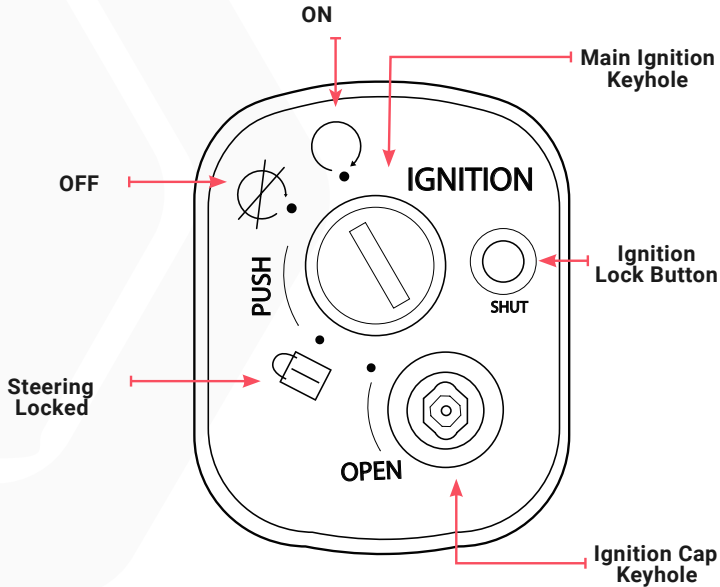

#### Main Ignition Keyhole

To turn ON/OFF the bike and lock the steering.

#### Ignition Lock Button

Press the button to block the main ignition with the ignition cap.

#### Ignition Cap Keyhole

To open the ignition cap.

# Operation Guide

## 9. How to turn on the bike

### a. Key Ignition

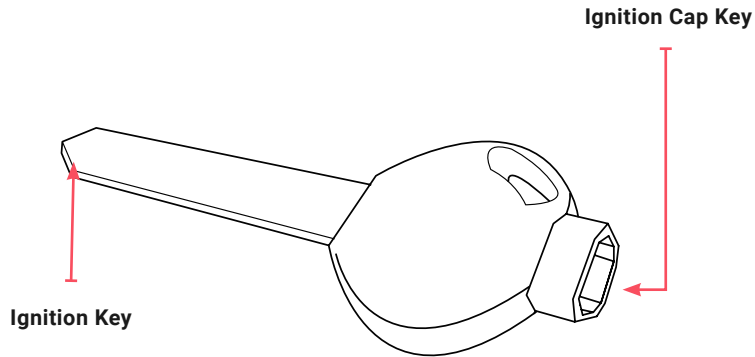

<b>Ignition Key</b>	To Turn ON/OFF the bike, to lock the steering, to open the seat, to open the small floor panel.
<b>Ignition Cap Key</b>	To open the ignition cap.

# Operation Guide

## 9. How to turn on the bike

### a. Key Ignition

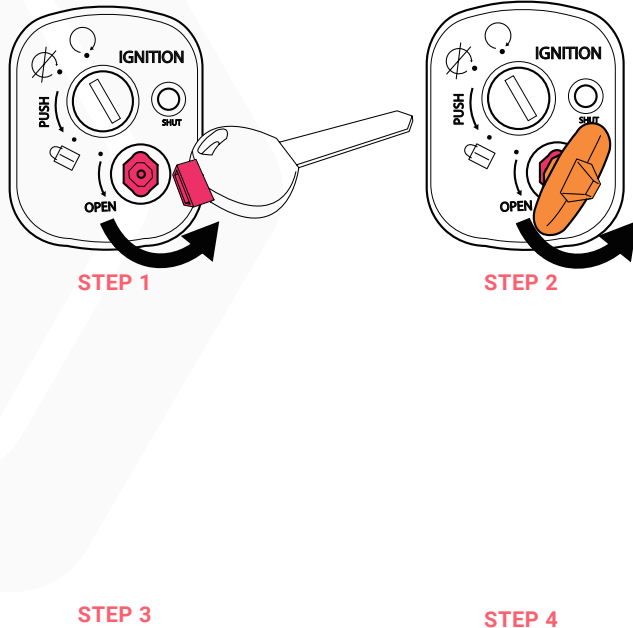

**STEP 1.** If the main ignition keyhole is blocked, you need to open the ignition cap first.

**STEP 2.** Follow the marking on the ignition, use the bottom of the key to open the ignition cap.

**STEP 3.** Insert the Key.

**STEP 4.** Follow the marking on the ignition, turn the key to the right to turn on the bike.

# Operation Guide

## 9. How to Turn on the Bike

### b. Remote

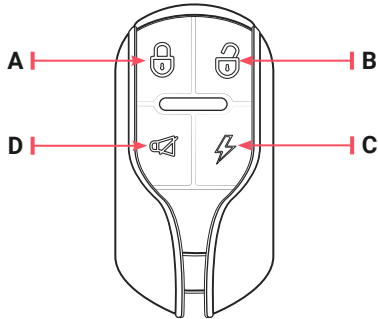

<b>A</b>	Lock Button	Press the button once to activate the anti-theft alarm system.
<b>B</b>	Unlock/Cancel Button	Press the button once to cancel the alarm or to turn off the bike if the bike is turned on with the remote.
<b>C</b>	Power Button	Press the power button <b>twice</b> to turn on the bike with the remote.
<b>D</b>	Panic Button	Press it once, the bike will sound 5 times.

### **!** NOTICE:

- By holding the unlock button, you can adjust the sensitivity of the alarm. 1 'beep' means least sensitive, while 5 'beep's means most sensitive. (This function may not be available in bikes sold in certain areas.)
- If the alarm system is on, please cancel the alarm before you turn on the bike.

# Operation Guide

## 10. How to lock the steering

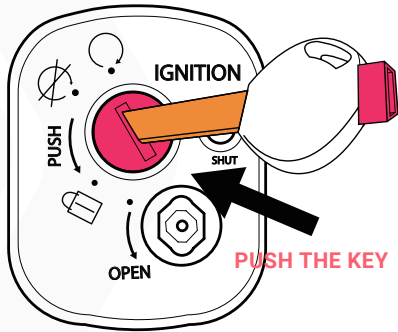

STEP 1

**STEP 1.** Turn the ignition off.

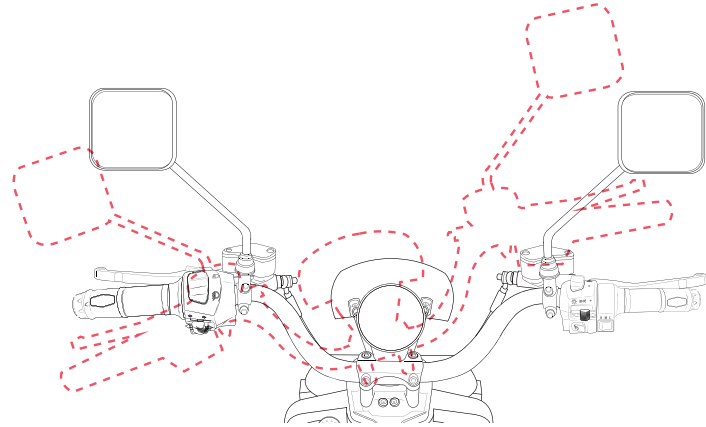

STEP 2

**STEP 2.** To lock the steering, turn the handlebar to the left.



**NOTICE:** For the safety of your bike, it is highly recommended of the steering when you park your bike in public spaces.

# Operation Guide

## 10. How to lock the steering

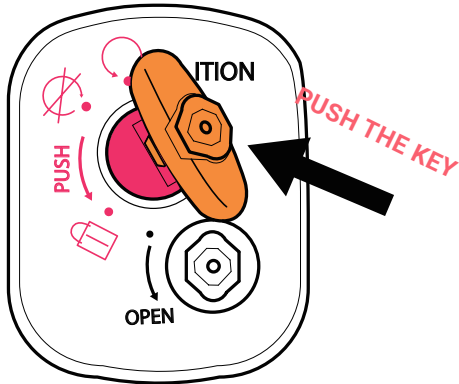

STEP 3

**STEP 3.** Push the Key in.

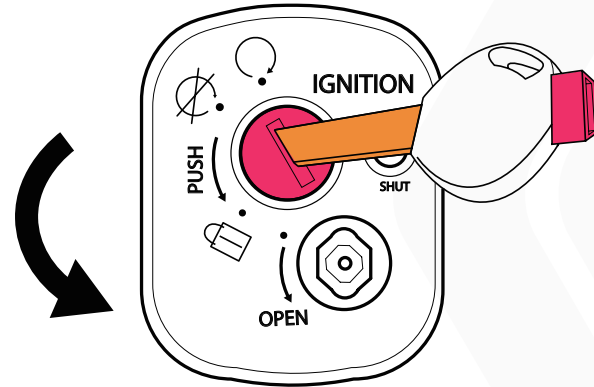

STEP 4

**STEP 4.** Follow the mark on the ignition, turn the key anti-clockwise.

**!** **NOTICE:** For the safety of your bike, it is highly recommended to lock steering when you park your bike in public space.

# Operation Guide

## 10. How to lock the steering

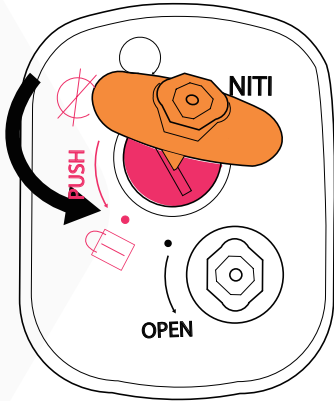

STEP 5

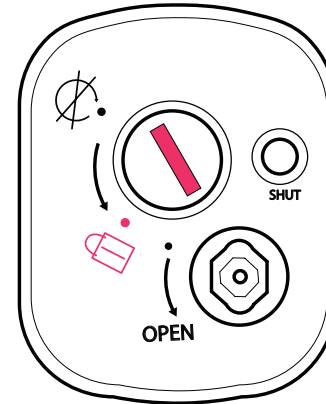

STEP 6

**STEP 5.** Remove the key when the steering is locked.    **STEP 6.** The steering cannot be turned when locked.

**! NOTICE:** For the safety of your bike, it is highly recommended of the steering when you park your bike in public spaces.

# Operation Guide

## 11. Circuit Breaker

Located in the storage compartment under the seat, the circuit breaker is the main switch of the bike. When it is turned off, the battery will be disconnected from the system and you will not be able to use the bike, nor will you be able to charge the bike.

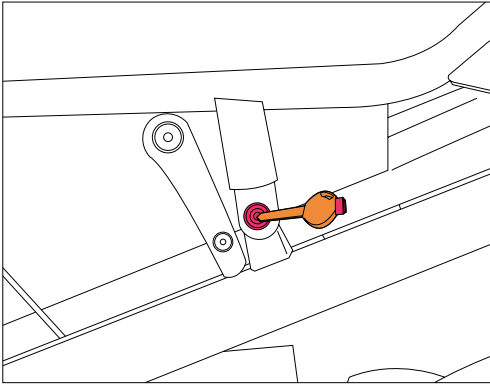

**STEP 1**

**STEP 1.** The seat lock is located on the left side of the bike, blow the seat cushion.

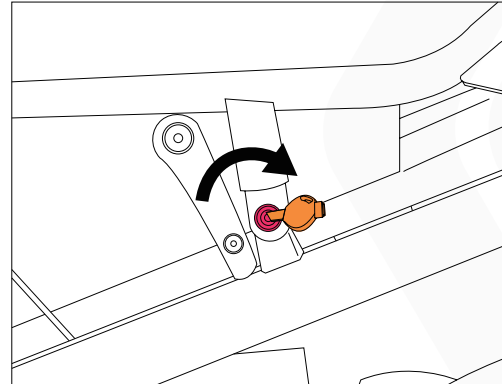

**STEP 2**

**STEP 2.** Insert the key and turn the key to unlock the seat lock.

# Operation Guide

## 11. Circuit Breaker

Lift up the seat, the circuit breaker is located on the wall of the storage compartment.

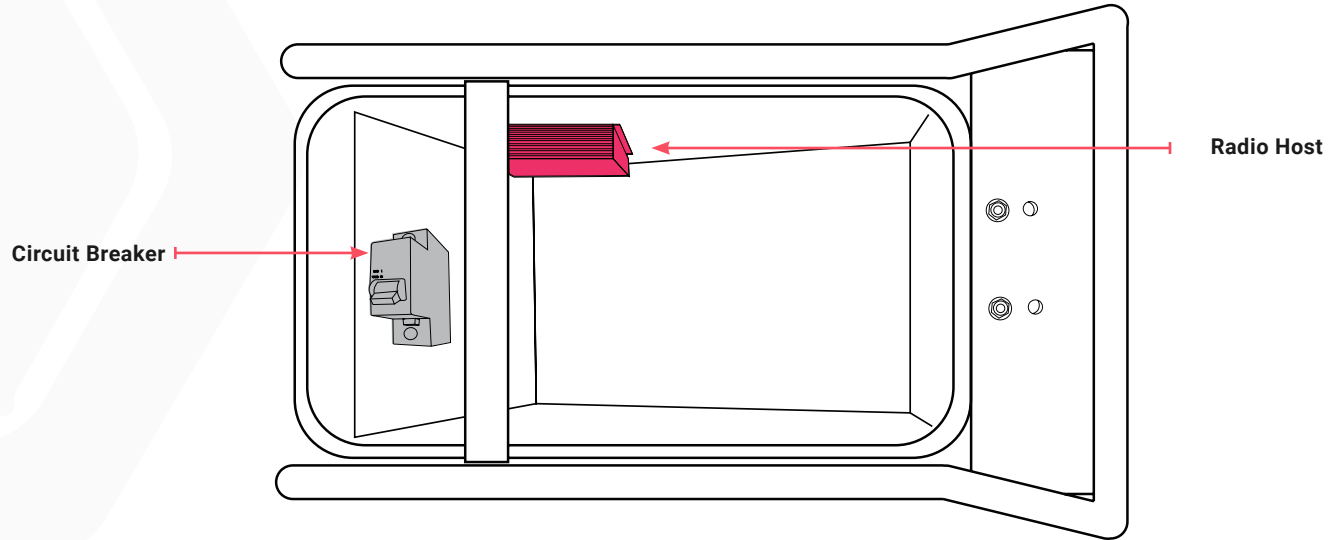

# Operation Guide

## 11. Circuit Breaker

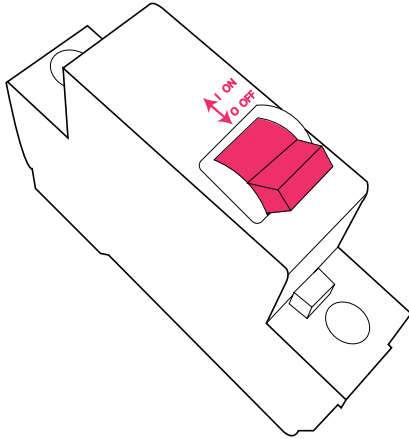

STEP 1

**STEP 1.** Follow the marking on the circuit breaker, switch the circuit breaker off.

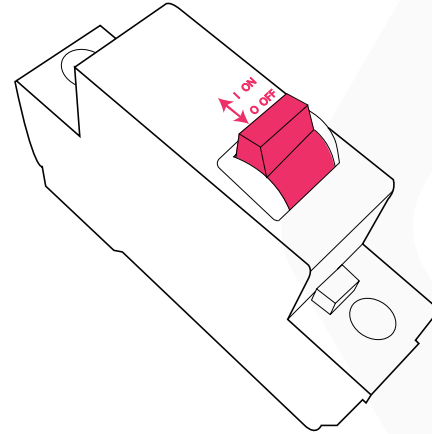

STEP 2

**STEP 2.** Before you want to charge the bike/use the bike, switch the circuit breaker on.

# Operation Guide

## 11. Circuit Breaker

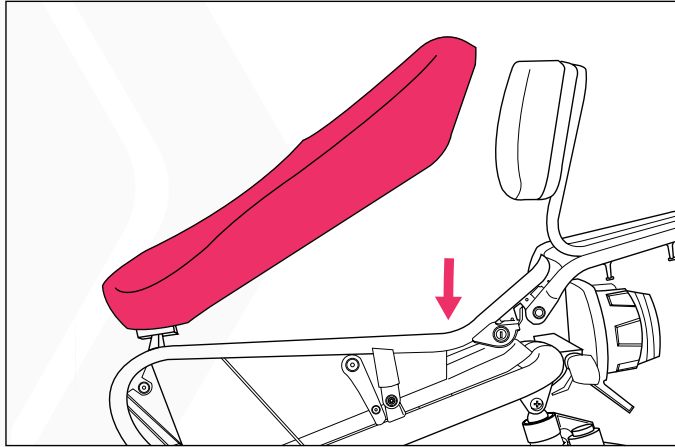

Gently push the seat sushion down to lock it.

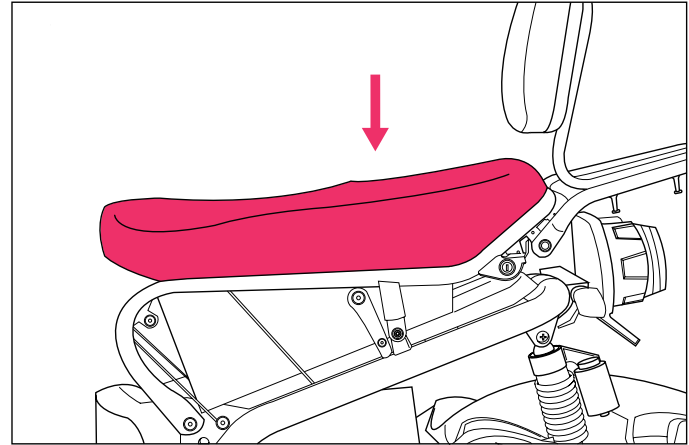

- Pay attention to the location of the U shape latch under the seat. That is the pushing point when you lock the seat.

# Operation Guide

## 11. Circuit Breaker

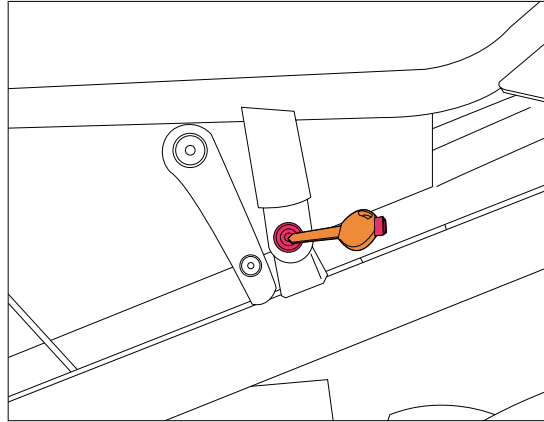

Remove the key after the seat is locked.



**WARNING:** The wires inserted into circuit breaker could have high voltage output. DO NOT touch any bare wires. If you have any concern, contact your EMMO dealer for assistance.

# Operation Guide

## 12. How to charge

### a. Lead Acid Charger

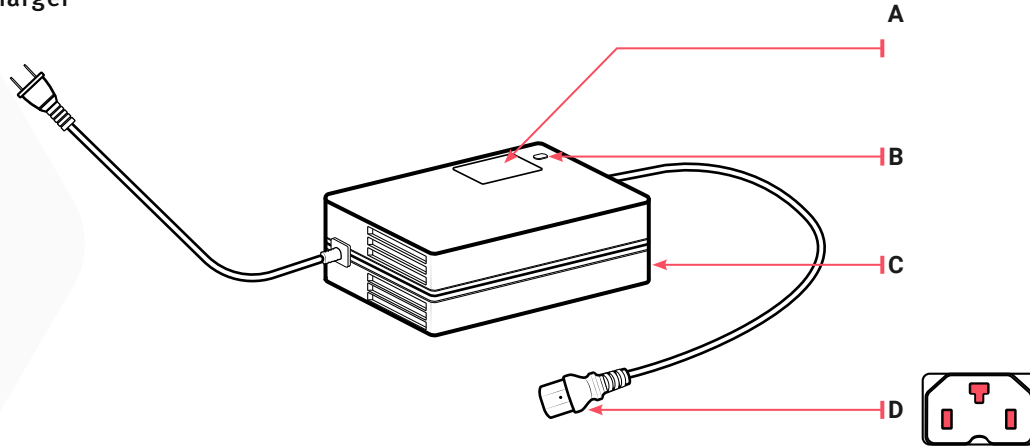

- |          |                             |
|----------|-----------------------------|
| <b>A</b> | Front Label                 |
| <b>B</b> | Charging Indicator          |
| <b>C</b> | Charger Specification Label |
| <b>D</b> | Charging Plug               |

# Operation Guide

## 12. How to charge

### a. Lead Acid Charger

On the charger, there is a sticker on the front indicating the voltage and capacity of the battery that the charger can be used for.

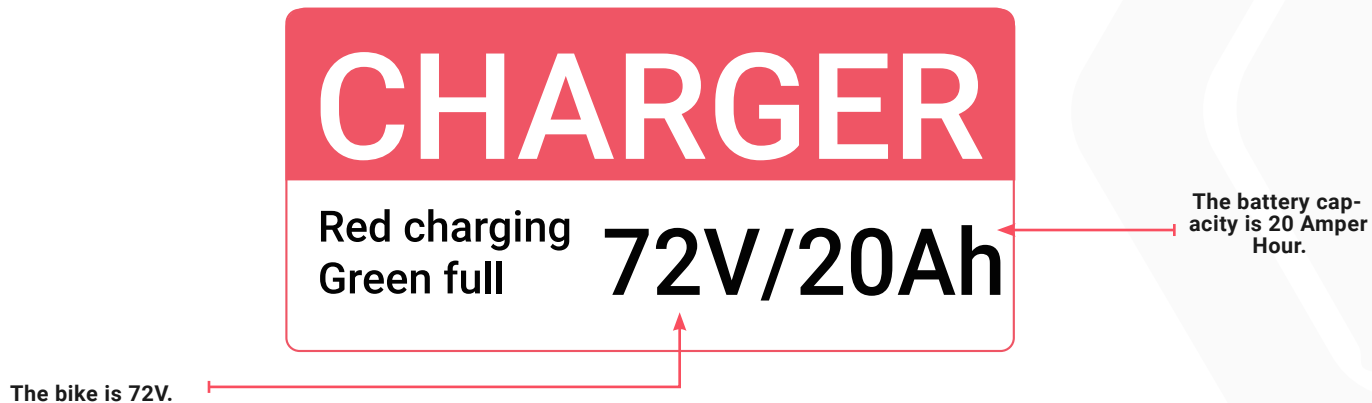

# Operation Guide

## 12. How to charge

### a. Lead Acid Charger

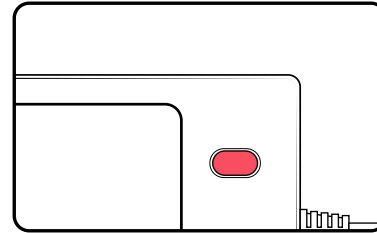
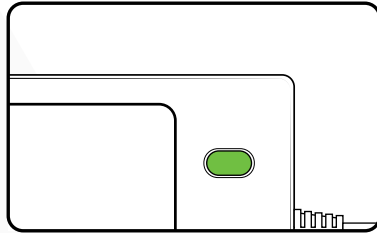

#### Charging Indicator Explanation:

- During normal charging, red light keeps on.
- The indicator will turn green when the battery is fully charged.

**!** **NOTICE:** If the charger gets warm during regular use, this is a normal response and is no cause for concern.

# Operation Guide

## 12. How to charge

### a. Lead Acid Charger

#### Charger Specification Label

## XCH - 7220 CHARGER

Be Suitable For 72v20ah Lead Acid Battery  
Input: 110V AC 50/60HZ,2A  
Output: 88.0V DC --- 2.6-3.0A



### User Guide

1. First of all please check whether the battery is suitable for the charger .whether positive and negative could match or not. Otherwise, When you use the charger , please connect the charge r.
2. During charging, indicat or light is red, Whe n the battery is full, the indicat or light is green .
3. Charging finished, you must unplug the powe r, and then unplug the output plug .
4. Charing Time: 4 to 10 hours (depending on the capacity of battery).

### WARNING



1. There is high voltage power, dangerous! Unauthorized disassembly is forbidden and wet hand could not be touch with power plug. Otherwise, please don't use it in the environment or moist, inflammable gas and explosive atmosphere.
2. Please don't insert any metal in to the charger, and store in a dry warehouse, and keep from rain.
3. During charging, keep open or ventilation .
4. If the charging time is over 36 hours or it is unwatched, please shut off the power immediately.
5. Avoid carrying the charger at all times, because violent vibrations will damage the charger .
6. If the charger is failed, please contact the supplier immediately .
7. If the indicator light is still red, not green light, after 12 hours charging, please add supplementary acid for battery immediately .

# Operation Guide

## 12. How to charge

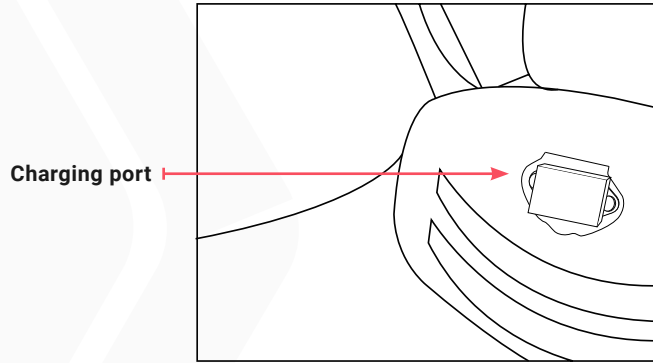

STEP 1

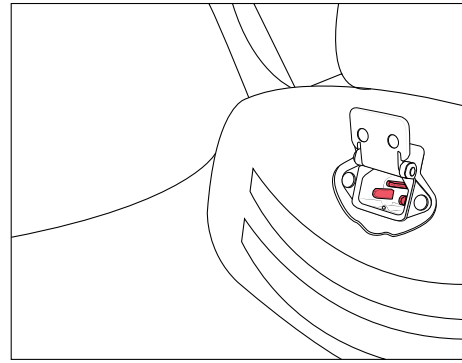

STEP 2

**STEP 1.** The charging port is below the front of the seat. **STEP 2.** To charge the bike, open the charging port lid.

**!** **NOTICE:** Please refer to Appendix 2 for more details of the indicators on chargers.

# Operation Guide

## 12. How to charge

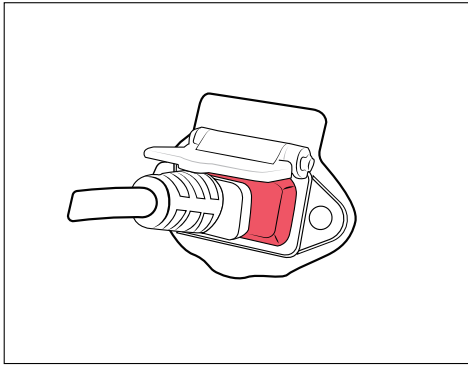

**STEP 3**

**STEP 3.** Plug in the charger and plug the charger into a regular 10V wall outlet.

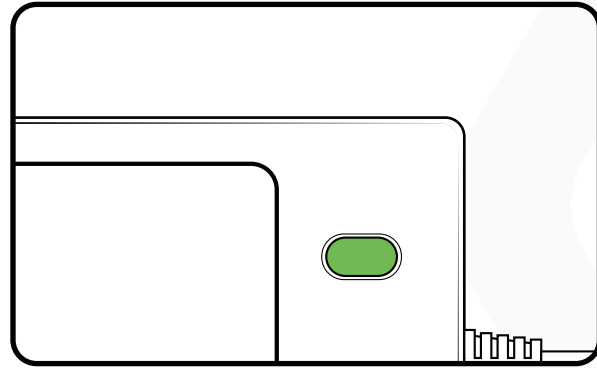

**STEP 4**

**STEP 4.** Once fully charged\*, unplug the charger from the wall outlet first and then unplug it from the bike.

# Operation Guide

## 12. How to charge

### b. Lithium Charger

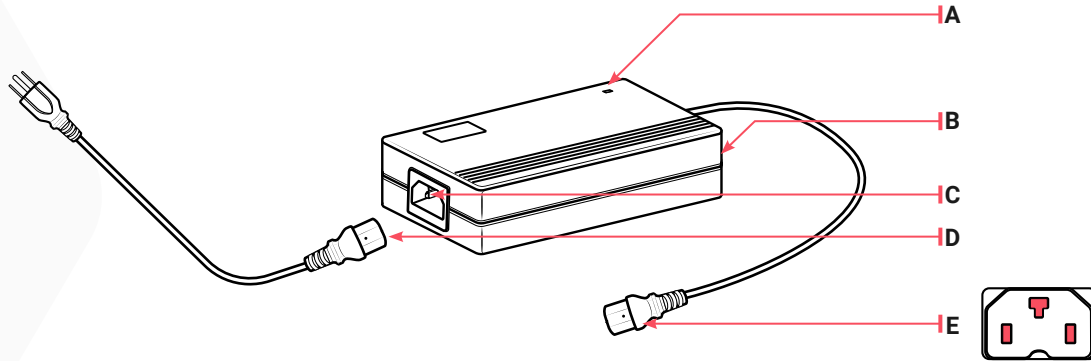

**A** | Charging Indicator

**B** | Charger Specification Label

**C** | Power Cord Socket

**D** | Power Cord

**E** | Charging Plug

# Operation Guide

## 12. How to charge

### b. Lithium Charger

#### A. Charging Indicator

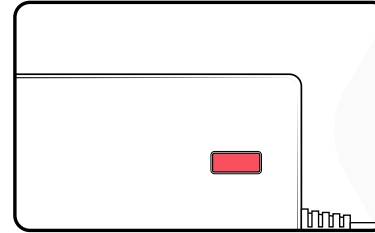
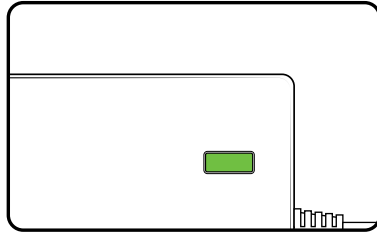

#### Charging Indicator Explanation:

- During normal charging, red light keeps on.
- The indicator will turn green when the battery is fully charged.

**!** **NOTICE:** If the charger gets warm during regular use, this is a normal response and is no cause for concern.



# Operation Guide

## 12. How to charge

### b. Lithium Charger

#### C. Power Cord Socket

#### D. Power Cord

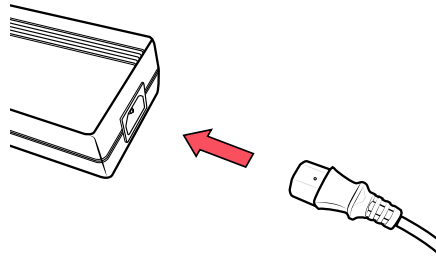

#### Connecting the charger:

- Plug the device connector **C** of the power cable into the device socket **D** on the charger.
- Before using the charger, plug the power cord C to the power cord socket D.



**WARNING: DO NOT** plug the power cord directly to the bike/battery. High voltage may damage the bike/battery and cause severe injury.

# Operation Guide

## 12. How to charge

### b. Lithium Charger

#### E. Charging Plug

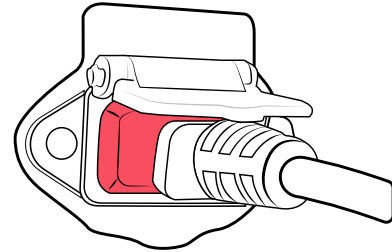
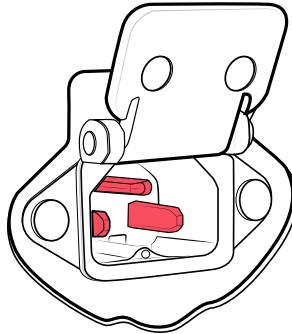
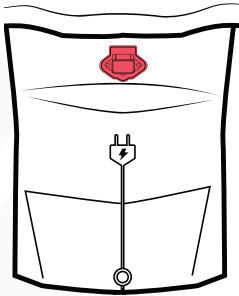

#### How to charge:

- The charging port is below the front of the seat. (Refer to ["side view", on page 10.](#))
- Open the charging port lid and plug in the charger.
- Plug the charger into a regular 110V wall outlet.

# Operation Guide

## 12. How to charge

### b. Lithium Charger

#### How to Remove the Underseat Battery and Charge it off the Bike

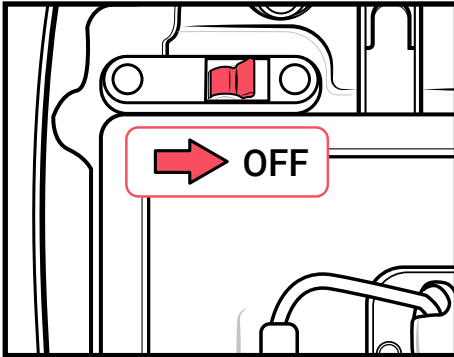

I. Open the seat, switch off the circuit breaker. (Red)

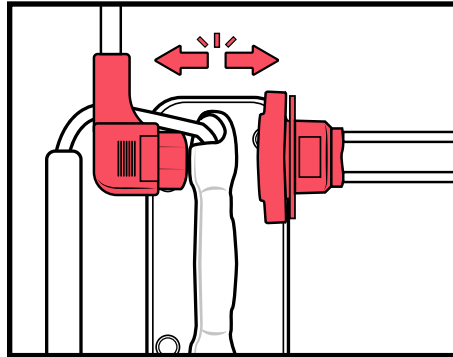

II. Disconnect the power plug.

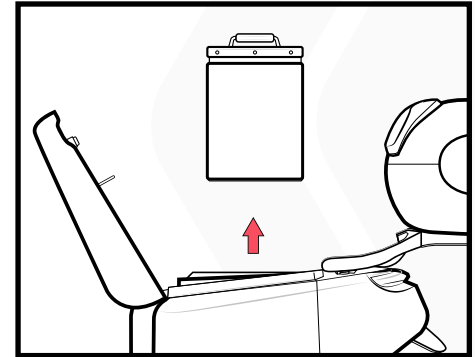

III. Take out the battery from the

# Operation Guide

## 12. How to charge

### b. Lithium Charger

#### How to Remove the Battery and Charge it off the Bike

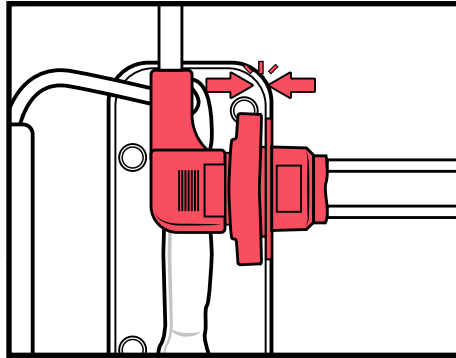

bike.  
**IV.** Connect the charging plug with

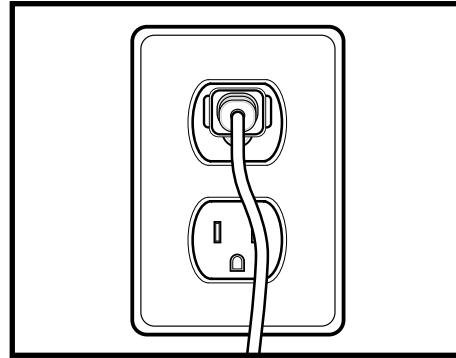

battery.  
**V.** Connect the charger with power

# Operation Guide

## 12. How to charge

### a. Charging Precautions



#### **WARNING: Battery & Charger Safety**

- The charger should only be used **indoors** in a cool, dry, ventilated area. Always position the charger on a **non-flammable surface** (e.g., concrete or brick), as it may generate heat during peak charging cycles.
- You must use a dedicated **110V outlet** to charge your battery.
- Never cover the charger during charging or leave it unattended.
- Keep the battery and charger away from children, pets, water, and open flame.
- DO NOT submerge or allow the charger to be submerged in water or any liquid.
- **DO NOT** use the charger or battery if **any part of the cord, connector, or housing is frayed, cracked, exposed, or otherwise damaged**. Using damaged charging equipment or battery connectors can lead to malfunction, fire, or serious injury.
- Do NOT drop, strike, or expose them to shocks.
- Use only the charger supplied with the product or approved by EMMO.

- Disconnect promptly once fully charged. Do NOT charge for more than **12 hours**, whether the battery is full or not.
- If the battery is stored, check it at least **once a month**. If necessary, use the original charger to recharge the battery to about **75%**. Failure to perform regular checks or charging may result in malfunction or safety hazards.
- Disconnect immediately if there is a strange smell, smoke, or overheating.
- In the unlikely case of battery fire: **never use water**. Use sand to cover the fire and call emergency services.
- **Battery & Charger Rated Life Expectancy:** Lead-Acid Battery: 2 years (500 cycles); Lithium-Ion Battery: 4 years (1000 cycles); Charger: 4 years. All component lifespans assume normal use and proper maintenance. **Annual inspection & safety testing by an authorized technician are required to ensure safety.** Components that have exceeded their rated service life—or no longer provide expected performance—should be replaced to ensure safety and reliability. While proper care may extend usable life, this can NOT be guaranteed.

# Operation Guide

## 12. How to charge

### a. Battery Safety Precautions



- Be sure to use the original/compatible battery (approved by EMMO). Using batteries from other brands may lead to severe accidents.
- Inspect the battery for any damage, leaking, overheating or smoking.
- Always charge between **0°C to 45°C**, charging outside of this range may cause permanent damage to battery.
- **DO NOT** lift the battery by its connectors or cables.
- **DO NOT** charge the battery for over 12 hours.
- **DO NOT** subject the battery to impact.
- **DO NOT** subject the battery to water.
- **DO NOT** subject the battery to heat or open fire.
- **DO NOT** open the battery pack by yourself. If you need any assistance, please contact your EMMO dealer.

[Refer to: Battery & Charger Safety for proper and safe use of battery & charger](#)

# Operation Guide

## 12. How to charge

### b. Disposal



This product contains sealed lead acid batteries which must be disposed or recycled in an environmentally safe manner. Do not dispose of the batteries in your household trash. Do not dispose of the batteries in a fire, this could cause the batteries to leak or explode. The incineration, disposal in landfill and or placing sealed lead acid batteries with household trash is prohibited by law in most areas.

### **!** NOTICE:

- Used batteries must be treated as hazardous waste.
- Batteries must be disposed of in accordance with the the regulations set forth by your local government/organizations.
- In case of uncertainty, contact EMMO customer service department.

# Operation Guide

## 12. How to charge

### c. Storage & Maintenance

- For storage, please disconnect the battery from the bike and charge the battery on a regular basis (at least once a month).
- Battery packs and chargers need to be stored in a clean, dry, ventilated place, avoid contact with corrosive material, and keep them away from heat and fire.
- Battery storage condition: Temperature:-20 - 35°C , humidity ≤ 65%RH.

# Troubleshooting

Potential Issues/Errors	Most Common Way To Solve Issue
Battery not fully seated in tray	Install battery correctly
Insufficient battery power	Need to recharge/test.
Faulty connections	Reinstalling or testing battery/wiring.
Improper turn on sequence	Clean and reconnect connectors
Brakes are applied	Try restarting the ebike.
Electrical cable unplugged	Repair or replace
Walk mode stopped	Ensure nothing is keeping any button(s) other than the walk mode button pressed on the UI Remote (on some models)
Control button(s) held	Ensure nothing is keeping any button(s) pressed on the UI Control (on some models)
Battery non-functional	Replace battery
Damaged or disconnected pedal assist sensor	Replace or reconnect pedal assist sensor
Loose wiring	Repair and or reconnect
Loose or damaged throttle	Tighten or replace
Loose or damaged motor plug wire	Secure or replace motor plug wire
Damaged motor	Repair or replace

# Troubleshooting

Low or faulty battery	Check connection, charge or replace battery
Low tire pressure	Adjust tire pressure
Climbing too many hills, strong headwind, braking, and/or excessive load	Adjust your route or assist with pedals
Brakes rubbing	Adjust the brakes
Battery discharged for long period of time without regular charges, battery is aged, damaged, or unbalanced	If range decline persists; contact local dealer
Insufficient battery power	Charge or replace battery
Loose or damaged motor wiring	Reconnect or replace motor
Loose or damaged wheel spokes or rim	Tighten, repair, or replace
Battery damaged	Replace
Charger not well connected	Adjust the connections
Charger damaged	Replace
Wiring damaged	Repair or replace
Blown charger fuse	Replace charger fuse

**!** **NOTICE:** If you have any questions, please contact your local dealer.

# Recommended Torque Values

Area		Tool	Rec. torque
<b>Handlebar</b>	Stem clamp bolts	5 mm Allen	10 Nm
	Stem faceplate bolts	5 mm Allen	6 Nm
	Stem angle adjustment bolt (side)	5 mm Allen	12 Nm
	Stem angle adjustment bolt (bottom)	5 mm Allen	15 Nm
	Speedometer clamp bolts	3 mm Allen	3 Nm
	Remote clamp bolt	3 mm Allen	3 Nm
	Throttle clamp bolt	3 mm Allen	3 Nm
	Shifter clamp bolt	Phillips or flat head	6 Nm
	Brake lever clamp bolts	5 mm Allen	6 Nm
<b>Brake</b>	Caliper adapter to frame	5 mm Allen	6–8 Nm
	Caliper to adapter	5 mm Allen	6–8 Nm
	Brake pads to caliper	Cotter pin	n/a
	Brake rotor to hub	T25 Torx bit	7 Nm
<b>Seat</b>	Seat adjustment bolt	6 mm Allen	15 Nm

# Recommended Torque Values

<b>Frame Downtube</b>	Controller mounting bolts	6 mm Allen	3 Nm
	Frame cable cover bolts	2.5 mm Allen	tighten securely; do not overtighten
<b>Rear dropout</b>	Rear axle nuts	18 mm wrench	40 Nm
	Torque arm bolt	4 mm Allen	5 Nm
	Derailleur hanger mounting bolt	5 mm Allen	10 Nm
	Derailleur mounting bolt	5 mm Allen	10 Nm
	Derailleur cable clamp bolt	5 mm Allen	6-8 Nm
<b>Bottom bracket and crank</b>	Pedal into crank arm	15 mm pedal wrench	35 Nm
	Crank arm removal info	Crank puller for square taper bottom bracket	n/a
	Crank arm bolt into bottom bracket spindle	8 mm Allen	35 Nm
	Freewheel removal	Contact local dealer	n/a
	Chainring bolts	5 mm Allen	10 Nm
	Kickstand mounting bolts	5 mm Allen	8 Nm
	Bottom bracket and cups	BBT-22 Park Tool	60 Nm

# Tools and Torque Values

<b>Accessories</b>	Headlight/front fender mounting bolt	5 mm Allen and 10 mm wrench	6 Nm
	Fender mounting bolts (except at headlight)	4 mm Allen	6 Nm
	Replaceable rear rack mounting bolts	5 mm Allen	6 Nm

# Riding Guide

## 1. Checking List Before Riding

- Whether the handlebar is stable and flexible when turning.
- Whether the right and left switches on the handlebar can work properly or not.
- Whether the throttle can work properly or not.
- Make sure the tires are inflated to the recommended tire pressure (30 PSI).
- Check tire surface, make sure there are no cracks, damages, and foreign matter punctures or attachments.
- Check whether the tread depth is enough, for your safety, tires should be replaced when the tread depth is below the recommended value by the manufacturer.
- Whether any error warning light are on the speedometer.
- Whether the battery capacity is enough for your trip.
- Whether all lights work properly or not.
- Whether the horn works properly or not.
- Whether the mirrors are clean and adjusted to the appropriate angle.
- Whether the brake lever and brake system work properly or not.

# Warranty Policy

**By purchasing any Emmo Inc products or other brand items sold by Emmo Inc, the customer agrees to the policies and procedures outlined below.**

Terms and conditions apply for eligibility of warranty. Please refer to [Terms and Conditions](#).

Any warranty is extended to the original owner with the original purchase paperwork. This portion does not cover the purchase of parts or the purchase of products sold by Emmo Inc that is not an electric bike, electric scooter ebike, electric motorcycle style ebike, electric mobility scooter, kick-style electric scooter, or ride-on toy.

## Electric Scooter

Emmo dealers may charge an assembly fee to assemble the ebike.

- Comprehensive Warranty (up to 4000km) There is a Two Year warranty (up to 4000km) for the frame, and motor. One year repair or part replacement is extended to the original owner on controller and other applicable components against manufacturer's defect in workmanship and materials on the e-bikes.
- Manufacturer's comprehensive warranty does not cover such parts including, but not limited to: seats, plastic housings and shrouds, pitting, scratches and chips, brake pads, tires, tubes, or damage due to lack of maintenance, accident, misuse or abuse. Damage incurred from water, road salt and other foreign debris or chemicals are not covered by the comprehensive warranty. The labour of any warranty repair will be covered by the original store that the bike was purchased from only when it is being repaired at said store. The parts will be covered by Emmo Inc. You are responsible for providing original purchase paperwork and shipping

the item to and from the store.

## **Purchased Parts**

Please consult your Emmo dealer for more details of the parts policies.

- **Shipping Damage:** Emmo Inc will not be held responsible for any lost, stolen, or damaged items due to any delivery services or courier actions. Report any damage to Emmo Inc within 7 days of receiving the part with pictures for any shipping damage and proof of purchase. Please note the damage on the shipper's proof of Delivery prior to signing off on the shipment. Shipping damage is not covered by Emmo Inc if you choose your own shipping method or freight forwarder. The cost of shipping will not be covered under warranty unless Emmo Inc agrees in writing to cover the shipping cost.
- **Repair and Store Purchases of Emmo Inc Products:** Any warranty is extended to the original owner with the original purchase paperwork. Any return or exchange within 7 days must be in new, unused, and original packaging. The customer is responsible for notifying Emmo Inc of the return or exchange and the cost of shipping will not be covered under warranty unless Emmo Inc agrees in writing to cover the shipping cost. On all return and exchange items, a restocking fee of 20% will be withheld from the refund amount unless Emmo Inc has agreed to another arrangement in writing. The cost of the item minus the restocking fee will be refunded once the product is returned and determined to be returnable. Restocking fees are 20% of MSRP not including Taxes, Freight/Shipping or PDI. Items out of original packaging will not be accepted.
- **Part Warranty Policy:** All items with warranty must have a valid warranty sticker. For Lithium models, the chargers must match the lithium batteries. Emmo is not responsible for any damage resulting in using another brand or voltage of charger or using an Emmo item with items that are not sold by Emmo Inc. Within 7 days, any items defective by manufacturer quality and are under warranty can be replaced. After 7

days, any items defective in manufacturer quality and are under warranty can be repaired. Warranty does not cover damage due to lack of maintenance, accident, misuse or abuse. Damage incurred from water, road salt and other foreign debris or chemicals. The labour of any warranty repair will be covered by the original store that the Emmo Inc part was purchased from only when it is being repaired at said store. For repairs that are done on items that are not from Emmo Inc, only a 7-day Parts Warranty will be included.

- If the part was paid by financing, you are responsible for any cancellation fees or penalties charged by the third party financing company unless Emmo Inc has agreed to cover the fees in writing. The financing loan agreement will only be cancelled after Emmo Inc has received and approved the returned item.
- For repairs that are done on items that are not from Emmo Inc, only a 7-day Parts Warranty will be included. Emmo Inc is not responsible for items modified from its intended use or purpose resulting in damage to the ebike or injury to the customer or third party.

 **NOTICE:** If you have any questions, please contact your local dealer.

# Leave Us a Review

By sharing your experience with EMMO, you can extend your warranty for an extra **3 months for FREE**.

Your review will help us to continue providing great products and services, and help others understand how EMMO can make their life greener.

Thank you for choosing EMMO.



GET **3**-MONTH  
EXTENDED WARRANTY  
**FOR FREE**

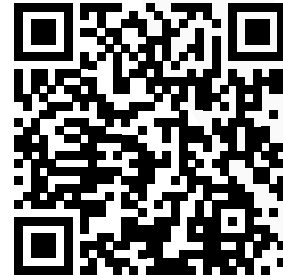

Scan the QR code to  
leave us a review.

# E-Bike Registration

## Survey:

**How did you find out about EMMO Inc.? (Please select the options that apply)**

- Returning Customer
- Family / Friend
- Passing by Store
- Kijji
- TERA
- Google
- Yelp
- Other \_\_\_\_\_

**2. Send the information listed above to our email: [info@emmo.ca](mailto:info@emmo.ca)**

**3. Wait for a confirmation e-mail from EMMO Inc.**

# Contact Us

## LOCATION

### **EMMO Mississauga**

1224 Dundas St E, Unit 6  
Mississauga, ON L4Y 2C5  
Canada

### **EMMO Vaughan**

1750 Steeles Avenue West, Unit 15-17  
Concord, ON L4K 1S6  
Canada

## **Contact**



**Toll Free:** +1-888-217-1217

**Email:** [service@emmo.ca](mailto:service@emmo.ca)

### **EMMO Toronto**

438 Spadina Ave, Unit 2  
Toronto, ON M5T 2G8  
Canada

### **Toronto Service Center**

438 Spadina Ave, Unit 5-6  
Toronto, ON M5T 2G8  
Canada

## **Website**



[www.emmo.ca](http://www.emmo.ca)

[www.emmo.ca/pages/contactus](http://www.emmo.ca/pages/contactus)

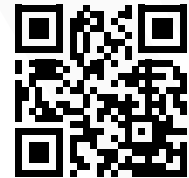



[WWW.EMMO.CA](http://WWW.EMMO.CA)