

Emmo Proton GTS

Owner's Manual



ABOUT EMMO

Emmo Inc. is a proud Canadian venture that is focused on creating a more sustainable future by providing high quality electric bicycles (otherwise known as “E-bikes”).

We offer a wide variety of E-bikes that are suitable for leading a greener, and more stylish, way of living within an urban setting. Emmo E-bikes are priced competitively with other green solutions. At Emmo Inc., we provide on and off-site repair services to better service our customers. We believe that to reach a greener future, we must provide quality goods to our customer.



Contents

Introduction	4
Bicycle Part Diagrams.....	5
Riding Instructions.....	7
Operating Instructions.....	11
The Battery.....	13
Charging your E-bike	14
Technical Data	17
EMMO E-bike Troubleshooting	20
EMMO E-bike Maintenance	23
E-bikes and Canadian Law	25

Introduction

E-Bikes

Riding an electric bicycle is a great way to hop around town conveniently and cheaply. E- Bikes represent a natural progression in the development of urban transportation.

Using only small amounts of electricity, e-bikes have the potential to radically reduce the amount of pollution in our cities. As well, they are very quiet, so they do not add to the high levels of noise pollution which we often take for granted. They are easy, and usually free to park. They are unobtrusive and highly practical additions to the urban landscape.

E-bikes are also inexpensive. They (currently) require no registration, no insurance, no licence and do not incur parking charges. As well, compared to internal combustion engines, the engines in electric vehicles have fewer moving parts and require far less maintenance.

Your EMMO e-bike is the result of EMMO's years of experience, the highly trained technical skills of our staff and careful, ongoing design work by our engineers. We hope you enjoy using this product and welcome any feedback that you may have.

New Laws

Most provinces in Canada, most states in the U.S.A, the United Kingdom and many European countries have new laws that permit cyclists to use electric motors to assist the regular operation of bicycles. Please check with your provincial or state government to learn about your local laws. At the back of this manual you will find the some of the common Canadian provincial regulations that govern e-bikes.

Liability

EMMO does not assume any liability for damages, loss of profits, or claims from third parties due to improper use of this product. EMMO does not assume any liability for damages due to problems with the product resulting from service by a third party that is not certified by EMMO.

The information in this guide may be subject to change without notice. For the latest information available, please contact your local EMMO dealer or visit our website.

We have taken all possible measures to ensure the accuracy and completeness of the information in this guide. However, if you do find anything missing, incomplete or wrong, do not hesitate to contact us.

Bicycle Part Diagrams

Diagram 1: The Proton GTS Electric Bicycle

This diagram illustrates the various parts of your bicycle. Please note that many of these parts are not user-serviceable and should be repaired only by trained professionals. This is especially true of the electrical systems and the mechanical components.



1. Seat
5. Rear Shock Absorber
9. Battery
13. Headlight

2. Taillight
6. Motor
10. Front Shock
14. Switch housing

3. Rear Fender
7. Controller
11. Rim
15. Handlebars

4. Wheel
8. Kickstand
12. Front Fender
16. Pedals

On/Off

Pushing this button turns the speakers on or off.

Mp3/FM

Pushing this button switches the input to your speakers – alternating between Mp3 and FM(FM radio is disabled)

Power and Selection Light

This light indicates whether or not the speakers are on. The light is on when the speaker is on and the light is off when the speaker is off. The light also shows the FM or MP3 work now.



Switchover

Use to switch the radio.

Volume Control

The 'V+' buttoning increases the volume of the speakers, while the 'V-' button decreases the volume of the speakers.

Pause or Play

Riding Instructions

This guide assumes that you already know how to ride a standard bicycle. Before you try to ride an electric bicycle, you should be very familiar with controlling and balancing a normal bicycle.

Caution

If you do not have cycling experience, an e-bike is too dangerous to ride. Do not begin learning to ride a bicycle using an e-bike.

Important Notes

- **E-bikes are Fast.** E-bikes are capable of traveling at higher speeds than many bicycle riders are accustomed to. Use caution at all times, especially when traveling in mixed traffic. Always take into account driving and traveling conditions.
- **Obey the Law.** Be sure to follow all provincial and city traffic laws. This includes obeying stop signs, checking carefully when turning, and riding defensively. An e-bike is a motorized vehicle, even though it is classed as a bicycle. You must follow the law.
- **Stay Sober.** Never ride your bicycle while intoxicated. An e-bike is capable of travel faster than a normal bicycle, and you should always be in control of it.
- **Your e-bike is capable of carrying one passenger in addition to the rider.**
- **Share the Road.** Be careful in mixed traffic. When on bicycle paths, traveling near pedestrians, or on recreational trails, try to be polite and courteous to those using the paths with you. E-bikes are new in most cities, so other users of the roads and recreational paths may not know how to deal with e-bike riders. Bear in mind that, in a sense, e-bike riders are “ambassadors” for this new method of transportation.

Items to Carry with the Electric Bike

It is a good idea to carry the following items with you at all times when you ride your e-bike.

- The charger, to charge the bike in case the battery power runs out
- 30 Amp Fuse, spares for the batteries, in case the fuses blow
- A lock, to secure your e-bike when you park it
- A helmet, as required by safety laws

Inspecting your Electric Bike

Always inspect your e-bike before you ride it, to make sure its safety features are operating properly. Many accidents can be avoided with routine inspections. Once you are comfortable with your e-bike, you will be able to detect small changes in the way it feels. If anything changes between uses, make sure to have it properly examined. Also, be sure to listen for changes in the sounds your e-bike makes over time. Any mechanical or power issues may have effects on the sounds the bicycle makes.

Holding the Handlebars

As with a normal bicycle or gas scooter, place your fingers over the brake levers, using the palms of your hand and your thumbs to wrap around and under the handle grips. Doing this allows you to activate the brakes easily, by squeezing your hand, in case you have to stop quickly. This is the safe way to control your electric bicycle.

Turning your E-bike On and Off

To turn on your e-bike, insert the key into the “ignition”, located just below the dash board, and turn the key to the right. When your e-bike is activated, the power indicator will light, and the battery charge indicator will jump, showing you how much power your e-bike has. To turn off the e-bike, simply turn the key to the left, and remove the key.

Warning

When you activate the e-bike, the electrical system becomes live. Do not try to affect changes to the E-Bike (such as removing the battery or repairing electrical components) while the E-Bike is activated. Turn the E-Bike off and remove the key before you attempt to access any of the electrical components. Also, the battery carries a significant electric charge and can injure people if not treated properly and with respect.

Accelerating and Decelerating

The throttle is found on the right-side hand grip on the handlebars. Turn the grip forward (away from you) to accelerate. To decelerate, release the grip (turn it towards you). Don't over-rotate the accelerator, as this could damage the battery and electrical components.

Warning

Do not activate the accelerator until you are seated on the bicycle and are ready to accelerate. The e-bike can easily escape from your control, possibly injuring you or others, and the e-bike may be damaged by being dropped.

Stopping

Your e-bike has two sets of brakes, at the front and at the rear. The levers attached to the handlebars, on the left and right, activate the brakes. Pull the levers toward you to activate the brakes.

You can use both brakes to come to a stop more quickly, or you can use one of the brakes to come to a gentle stop, depending on your riding needs at the moment.

When the brakes are activated, the power to the engine is automatically turned off, until you release the brakes. This allows you to stop safely.

Safety Tips

- When you are traveling in wet weather, water may cause your brakes to function less efficiently because it reduces friction between the brake pads and the wheels. Take care to slow down and give yourself more room to stop or slow if necessary.
- It is a good idea to have your brakes and brake pads checked regularly. The brake pads will eventually wear down through friction, and after significant use will have to be replaced.

Signaling

The Horn

The e-bike has a horn. The horn button is on the left handlebar. Simply press it to activate the horn.

Turning Signal Lights

Your e-bike has turn signal lights. The turn signal activator is on the left handlebar. Push it left or right to activate it to indicate that you are turning in the appropriate direction and press the middle of the button to turn it off. The turn signals also emit a noise, to ensure that everyone knows you are turning. This turn signal cannot be disabled without also disabling the visual signal.

Lights

The headlight and taillight are useful features when you are riding at night or in dark areas. They radically improve your safety in mixed traffic. The switch is located on the right handlebar. The lights on your e-bike consume some electricity. Keeping them on may reduce the maximum distance you can travel on one charge by about 5%.

Riding in Wet Weather

Your e-bike is designed to function in wet conditions, such as when it is raining. However, because the motor is on the rear wheel, it is easy to slip when moving at high speeds. If it is very wet, be sure to avoid high speeds.

When you are traveling in wet weather, water may cause your brakes to function less efficiently because it reduces friction between the brake pads and the wheels. Take care to slow down and give yourself more room to stop or slow if necessary.

The Motor and Water

Your e-bike is not designed to be immersed in water. Always ensure that the water level does not go above the middle of the tire, to prevent water from getting inside the motor.

Water in the motor can cause short-circuits and may damage the electrical systems in your e-bike.

Riding in Cold Weather

Your e-bike is designed to operate year-round. However, in very cold conditions or when there is a lot of snow or slush on the ground, it is possible for the motor in the e-bike to get wet or for the brakes to function less efficiently, just as can happen in wet weather. Below 10 degrees Celsius, the battery will not work as well as it would in warmer temperatures. While Lithium-Ion batteries perform better than Lead-Acid batteries in temperature extremes, both will experience reduced performance in cold temperatures.

Also, riding the e-bike in cold temperatures may require you to replace the battery sooner rather than later.

Operating Instructions

Using the Rear Storage Compartment

The rear storage compartment is opened using the key provided to you when you purchased your e-bike. Insert the key and turn it to the right to open the compartment. Close the case and turn the key in the opposite direction to lock the compartment again. You can use this compartment to store the charger and associated cables, so you can recharge your e-bike if it runs out of power. It can also hold a locking mechanism, such as a u-lock, for added security when parking your e-bike. The space provided is perfectly suited for these purposes.

Opening the Seat Trunk

To open the seat trunk, insert the key into the lock on the left side of the e-bike just below the seat. Turn it all the way to the right. The seat will snap open and pop up.

To close the seat trunk, make sure that there is nothing blocking the locking mechanism, such as items you have placed in the storage compartment, and push the seat down with force. You will hear a “click” sound when it is properly closed.

Parking and Locking your E-bike

When you want to park your e-bike for a short time, either when you have reached your destination or are at home, follow these steps:

1. Stop the e-bike and position it as you want it.
2. Get off the e-bike, making sure to keep it balanced.
3. Stand to the side and slightly to the rear of the e-bike.
4. Hold the kickstand with one foot, and hold on to the e-bike by the rear basket bracket. This bracket is made of metal and will hold the e-bike’s weight.
5. Pull the back of the seat up and towards you. The e-bike will move backward. The kickstand will hold the e-bike in place and anchor the bike.
6. Lock your e-bike to a bicycle locking post or other secure objects through the rear wheel frame or one of the metal frame components.

Warning

Do not let your e-bike drop or fall. The exterior may be damaged. The fall may damage

other components inside the e-bike, as well.

Maximum Load

Do not exceed the maximum load capabilities of your e-bike. You can find the exact loading capacity listed in the technical specifications in this guide.

If you exceed the maximum load, the performance of the bike will suffer.

Exceeding the maximum load of your e-bike could cause damage to the shocks, to the mechanism and, ultimately, even to the frame. It could also cause your motor to work too aggressively, and it may burn out.

Disconnecting the Circuit Breaker

When the circuit breaker is disconnected, all power from the battery to the e-bike is blocked. This is useful if you are going to store your e-bike or if it is damaged and you wish to bring it to be serviced.

Disable the circuit breaker using the following very simple procedure.

1. Open the seat compartment.
2. Find the circuit breaker switch (it should be obvious).
3. Activate the switch. The power to the e-bike will be disabled.

Long-Term Storage of your E-bike

If you are storing your bike for a long period, disconnect the circuit breaker. This is a safer way to store the electric bicycle, as it prevents accidental activation of the e-bike and makes it impossible to activate it even with the key. The circuit breaker is found by opening the battery case. It sits between the battery and the controller.

Please see the section titled “Your Battery” for instructions on battery maintenance while your e-bike is being stored.

**Your bicycle may or may not have a circuit breaker. If it is not clearly visible in the seat compartment, it is likely that your bike does not have a circuit breaker and thus this section does not apply*

The Battery

This section details what you need to know about the battery that powers your e-bike. Always remember to treat your e-bike's electrical systems with respect.

Battery Power

The dashboard has a battery charge indicator. When the e-bike is activated, the needle will jump and indicate the currently available battery power.

If the power has dropped significantly, you should charge your e-bike.

Distance and Power

Your battery has the capacity to carry you anywhere from 35 to 70 km before it must be recharged. The ability of your battery to power your bicycle depends on many variables. These variables include the weight of the rider, the prevailing wind resistance, the rider's driving habits, the presence of steep hills and inclines, and other issues such as proper air pressure in the tires.

Saving Power

If you are traveling long distances, you can save a lot of electricity by using better driving habits.

- **Coasting:** When going downhill or overlong, flat road surfaces, try using your e-bike's momentum and allow it to coast, without drawing power from the motor.
- **Stopping and Starting:** Try to avoid stop and go movements. The motor draws more power when starting from a full stop.
- **Weight:** Remove unnecessary weight from the bike. This reduces the amount of power the motor must draw.
- **Air Pressure:** Make sure your tires have the proper air pressure. Proper pressure reduces drag on the tires and radically increases the efficiency of any vehicle.
- **Head and Tail Lights:** Turn off the lights to conserve power, if it is safe to do so. The lights will reduce the distance you can travel by about 5%.
- **Pedaling:** When accelerating from a full stop, you might want to try pedaling to help acceleration

Charging your E-bike

Charging your e-bike is a simple process. You require the following.

- The charger that came with your e-bike.
- A 110V household electrical outlet.

Charger Warning

Only use the chargers that were supplied with your e-bike. Using chargers that do not have specifications identical to those which came with the e-bike could irreparably damage your e-bike's battery and electrical systems and may cause injury.

To charge your e-bike, follow these steps:

1. Turn off the e-bike and remove the key from the "ignition."
2. Plug the female end of the charger cable into the charging slot on the e-bike. This is found on the outside casing of the e-bike, in front of and just underneath the seat.
3. Plug the male end of the charger power cable into your wall socket. This should be a 110V household electricity supply. You can also use a portable generator, if necessary, but make sure it provides 110V current.
4. Allow the e-bike's battery to charge for the appropriate amount of time (6-12 hours).
5. Disconnect the charger when the LED light on the charger is green. The batteries have been fully charged.

If your charger's LED status light does not change from red to green over an extended period, for perhaps more than 14 hours, and the battery is very hot, the battery or charger may need replacing. Stop charging and bring both to your EMMO dealer immediately. Do not charge the battery.

Battery Care

Follow these suggestions to maintain your battery's optimal performance. If you do not follow these suggestions, your battery may lose its ability to maintain a charge and might have to be replaced sooner than would otherwise be necessary.

- **Charge it:** Charge your battery immediately after riding it.
- **Full Charge:** Do not allow the battery to run down completely and lie in storage without a charge. This significantly reduces the battery's lifespan and may cause damage.

- **Keep it Charged:** When being stored, charge the battery occasionally to make sure its power supply does not run down. Charging it once every 21 days should be sufficient.
- **Storage Conditions:** Store the battery on a flat, cool, dry surface. Do not allow the battery temperature to drop below 10 degrees Celsius for extended periods of time.

Warning

DO NOT place your Lead-Acid battery on concrete. Concrete drains the battery's power and will neutralize the lead-acid. Placing the battery on concrete for any length of time will likely result in the battery being drained of power and possibly losing its ability to store electricity.

Cold Weather and your Battery

Below 10 degrees Celsius, the battery will not work as well as it would in warmer temperatures. While Lithium-Ion batteries perform better than Lead-Acid batteries in temperature extremes, both will experience reduced performance in cold temperatures.

Also, repeatedly riding the e-bike in cold temperatures may cause your battery to have to be replaced sooner.

Handling the Battery

The battery contains large amounts of electrical power. You must use caution and respect when handling it. Not following these instructions can result in serious injury.

- Always lift the battery with both hands and carry it with care. Never drop the battery. If the case is damaged, the contents may leak out.
- Never puncture or open the battery case. The contents are dangerous and may cause injury. Do not touch the contents of a leaking battery. Seek help immediately.
- Do not touch the two metal poles on the battery box at the same time. This can cause a short-circuit. It could injure you or others and cause serious damage to the electrical systems in the e-bike. Your battery contains significant amounts of electrical power.
- Do not handle your battery if either you or the battery are wet. Water is an excellent conductor of electricity. You may experience an electrical shock, and you may be injured.

Replacement and Disposal

After approximately 300 charges, a lead-acid battery will need to be replaced. A lithium-ion battery will last approximately 1500 charges. When the battery has to be replaced, you will notice that your battery cannot carry as much of a charge as it could initially.

Contact your local EMMO dealer to purchase a new battery.

When replacing your battery, dispose of it at a proper municipal battery recycling facility. If none is available, please contact your local EMMO dealer.

Warning

Be sure that you replace the battery with an identical or very similar battery. While it is possible to change the battery format or power levels, this requires advanced knowledge of electrical systems. If improperly done, this can result in immediate and irreparable damage to the electronic controller and electrical systems. Be certain of what you are doing before you replace the battery with a different type of battery.

Using the wrong type of battery will also void your warranty.

Technical Data

This section provides you with the technical specifications for your e-bike.

The Motor and Wheel Assembly

The Smart Bike has a 500-Watt magnetic DC brushless motor on the rear wheel hub. This type of motor has excellent low-end torque and high efficiency when working within its range. Note that while the motor is very quiet, it does produce some noise. Also attached to the rear hub are speed reduction gear and the speed free clutch.

The Freewheel

The wheels have freewheels, so the e-bike's drive train is not fixedly geared. This means that when coasting or traveling downhill, you can turn off the engine and your e-bike will continue to move without slowing. This feature will allow you to achieve faster speeds when coasting, moving downhill or moving with the wind. It will also allow you to conserve electrical power because you will be able to let the motor rest while moving.

The Controller

EMMO electronic controller is located under the seat assembly. This controller efficiently regulates the speed and electronic functions of the bicycle. It allows for stepless speed adjustment, shuts off the motor when the brakes are activated, has low voltage protection and has fuses to prevent excess current from damaging the e-bike's systems.

The Governor

A key component of the controller is the Governor. The Governor regulates the speed of the e-bike. It prevents the motor from assisting riders when the e-bike's speed surpasses 32 km per hour.

The governor's primary function is to make sure that the motor functions efficiently. If the governor is not functioning, the mileage of the e-bike will be dramatically reduced, and its performance will suffer.

This speed limitation to 32 km per hour is required by government regulations.

Traveling faster than 32 km per hour through motor power alone is illegal in Canada and could result in serious fines or penalties, unless your vehicle is insured for liability, is registered and you are licensed to drive.

The Brakes

The brakes on your e-bike are disc brakes, like those found on gas scooters and motorcycles. They generally provide for very fine stopping and control, and this is a very tested and well-designed technology.

The Chain and Pedals

The pedals are connected to the rear wheel. Along with the chain, they provide a human-powered “drive train”. This is an important part of your e-bike. The pedals are not removable and should not be removed.

Shock Absorbers

Your e-bike is equipped with EMMO Shock System shock absorbers. These effective but simple devices absorb the energy from bumps and dips and allow you to have a much more comfortable ride. The EMMO Shock System is superior to normal shock absorbers usually found on e-bikes and provides for a much more comfortable ride.

While they are very resilient, please note that very sharp or large shocks, such as drops from a height of 15 cm or more, can cause serious damage to your shock absorbers. Replacing them is a complex and time-consuming task, so do be careful when dropping from larger heights.

Basic Statistics

Dimensions	Weight	Loading Capacity	Speed and Mileage
Wheel Size: 130/70/12 Body Size: 2080 x 790 x 1145	120 kg	Standard:80kg Maximum:290kg	Speed: 32km/h Mileage: 60km

Travel range is based on riding on level ground, no stops, no winds, warm temperatures for a 175lb rider with no extra cargo

Electrical System Statistics

Motor
Statistics
Voltage:72V

Working
Efficiency:70%-80%

Climbing
Angle: 35
Degrees

Charger
Statistics
Charger
Input:AC100-240V
Standard
Input
Voltage:
110V +/-
10%
Charger
Time:3-10
hours

Battery
Statistics
Type: Lead
Acid

Rated Voltage:
72V

Battery Life:
300 charges

Rated Total
Capacity:500W
h

Wiring Diagram

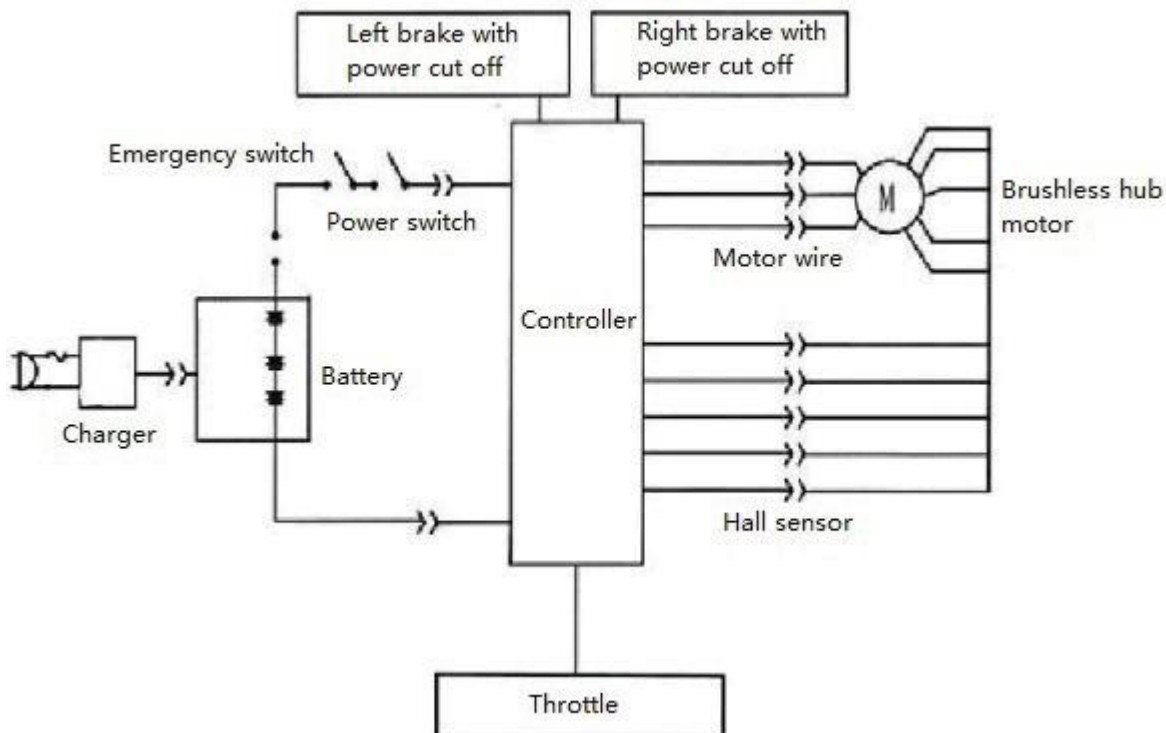

EMMO E-bike Troubleshooting

This section outlines problems you may have and solutions you may be able to use.

Many of the parts in this product are not user-serviceable and should be repaired by trained professionals. This is especially true of the electrical systems and the mechanical components. Alteration of these components voids the warranty.

Tire Pressure

Maintain the air pressure in your tires at the appropriate level. If the air pressure is too low, your e-bike's performance will suffer, and it will become damaged more easily.

Cold weather and lower temperatures will cause the air pressure in your tires to drop, and warmer weather will cause it to increase, even if there are no leaks in the tire tube. To replace the air in your tires, follow this procedure.

1. Identify the required pressure by examining the text along the side of the tire rim. This text should indicate the recommended pressure for your tire.
2. Locate the air valve on the inner surface of the tire rim.
3. Remove the valve cap and place in a secure location.
4. Place the nozzle end of an air pump (hand-power or mechanical) over the valve.
5. Pump up the air in the tire, being careful not to let the pressure go above the level prescribed on the side of the tire wall.
6. Remove the pump nozzle from the air valve without allowing much air to escape from the tire.
7. Replace the valve cap on the air valve.

Maintaining the proper air pressure will allow you to travel much further on a single charge because the motor will not have to work as hard to move the e-bike.

Replacing Flat Tires

Replacing flat tire tubes is a more complicated and labor-intensive process with e-bikes than it is with regular bicycles. It requires proper tools, more skill, and more patience. The front wheel is easier to service when changing a flat tire than the rear wheel, as the rear wheel is connected to the hub motor and other mechanical parts.

Unless you are very familiar with the mechanical components of the rear motor, attempting to change a flat rear tire may cause serious problems. Please contact your

EMMO dealer for specific instructions on how to remove your wheel and tires safely, and how to replace the tubes.

The Brakes

The brakes on your e-bike allow you to stop and are a critical safety feature. Make sure you test them regularly. Take the e-bike to your EMMO dealer if the brakes appear to be losing their stopping power or feel looser than they were previously.

The brakes on your e-bike may require servicing from time to time. The brake pads will need to be replaced as they wear down, usually after about a year to a year and a half or so, depending on how the e-bike is ridden. Also, the brake cables may have to be adjusted for tension.

You can only service the brakes yourself if you have extensive experience servicing brakes. Please do not attempt to service the brakes if you are not sure how to do it.

Warning

If your bike is drum brakes, do not excessively loosen the drum brakes. If you do not keep them sufficiently tight, your drum brakes will fail and your e-bike will not be able to stop properly.

The Motor

Do not service the motor yourself. Bring the e-bike to your EMMO dealer for service. The motor in your e-bike is a highly complex and fine-tuned mechanism. Repairing it requires significant expertise.

We suggest maintenance every 100 running hours or so.

The Chain

Ensure that the chain on your e-bike is well-oiled and lubricated. It is an important part of your e-bike. As with any bicycle, it needs to be maintained if it is to function.

Shock Absorbers and Comfort

If your riding experience feels bumpier than usual, and you suspect that your shock absorbers are experiencing difficulties, check the air pressure in your tires. If the air pressure is too low, this may be the reason you feel less comfortable. It may have

nothing to do with your shock absorbers.

If the problem persists, take your e-bike to your EMMO dealer for servicing.

Bring in your E-bike for Service

Do not attempt to service the electronic or mechanical parts of your e-bike unless you are sure of what you are doing and have a solid understanding of electrical and mechanical equipment.

If your e-bike is not performing properly, disconnect the circuit breaker and bring the e-bike to your local EMMO dealer.

Do not store the e-bike without disconnecting the circuit breaker.

Liability

EMMO will not be held responsible for damage or injuries resulting from errors resulting from improperly serviced parts.

EMMO E-bike Maintenance

Cleaning

Cleaning is extremely important this will ensure your e-bike will serve you for a long time. In the long run, it will save you money and a lot of time waiting for the bike to be repaired. You should clean your e-bike weekly.

Do not use aggressive power jets or water sprays when washing the e-bike and keep water off the battery as much as you can. Clean gently but thoroughly and make sure that all the outer casing of the electric parts is dry and clean.

Remove any dirt, debris, sand, mud, grit, grime that got caught on the bike and dry it off. While cleaning, it is a good opportunity to look closely for a worn, loose, cracked, rust, or damaged parts. Buckled paint can also be a hint for some parts that need closer inspection.

Lubricating

It is recommended to lubricate the chain, levers, derailleur, cables, etc. A clean, lubricated e-bike tends to be faster, smoother and quieter. It's like having a little extra push for free.

Apply the lubricant to the different parts and let it sit a few minutes and then wipe off the excess lubricant with a rag. After a while, clean the different parts with a degreaser to remove any excess dirt that has been collected.

Weather

Don't leave the bike out in the rain or snow.

Store it somewhere dry and out of direct sunlight. Overheating the batteries, for example, can cause problems.

Do not open up casings, chargers, etc. as you are unlikely to be able to reseal them effectively afterward, making them more susceptible to water damage and other extreme weather conditions.

Batteries should be removed from the e-bike if not used and charged once a month regardless of usage.

Schedule

The frequency of maintenance depends on how much you ride and under which conditions. Recreational riders need far less maintenance than off-road riders. The harder you ride, the more you have to take care of your bike if you want it to last. There are various time intervals for proper maintenance. Quick maintenance should be done before & after every ride.

Time after purchase	Action Suggested
Every time before you ride the 60 second check	Check tire pressure, check brakes that they work, check lights, check bolts (make sure everything is tight), check battery gauge. Do not ride the e-bike unless everything is functional and proper.
30 days (every month)	Completely clean the bike, including the dust on the motor and under the seat. Check for any abnormal wear and tear or alignment problems.
90 days (every 3 months)	Inspect frame and fork for paint cracks or bulges that may indicate frame or part damage; pay attention to all frame joints. Check wear and tear on tires. Check the range of battery.
180 days (every 6 months)	Inspect all components of the e-bike. Check that connections are nice and tight. Look inside where you controller is and clean in detail. Check that all plugs. Go over every bolt and nut in your e-bike.
360 days (every 12 months)	Bring e-bike for complete tune-up. Varying on the e-bike the e-bike shop should complete a battery discharge, tires should be changed depending on wear and tear. All connections should be checked for rust and looseness. All components should be checked including charger, ignition, and gauges.

E-bikes and Canadian Law

British Columbia, Alberta, Saskatchewan, Manitoba, Quebec, Nova Scotia, Newfoundland and Labrador, Yukon

Currently, eight Canadian jurisdictions (British Columbia, Alberta, Saskatchewan, Manitoba, Quebec, Nova Scotia, Newfoundland and Labrador and Yukon Territory) have legalized power-assisted bicycles for public road use and are treating these vehicles as conventional bicycles and not as motor vehicles. As such, they do not require insurance, registration or licences. E-bike technical specifications must fall within certain parameters, however,

The rules are similar in every province, with minor variations, and are not considered controversial. Consult your local ministry or department of transportation for guidelines.

New Ontario Regulations

Ontario is currently running a pilot program to determine whether or not e-bikes should be allowed on Ontario roads and under what conditions. The pilot program ends in 2009, at which point decisions will be made as to the future of e-bikes on Ontario roads. Because the program in Ontario is new, and the rules are often unfamiliar even to law enforcement officials, we have included a synopsis of the regulations here. These rules are very similar to the rules currently in place in other Canadian provinces. Print the “TPS Training Bulletin” at the end of this manual and keep it with you when you are traveling. If you are stopped by traffic authorities who are unfamiliar with e-bikes or the regulations concerning them, show them this bulletin. They should allow you to continue.

Definition of an E-bike

An e-bike is a bicycle with an added battery-powered electric motor that does not exceed 500 watts and can assist the cyclist up to a speed of 32 km/h. It can also be driven like a bicycle without any power assist. The addition of the power assist enables the rider to pedal with less effort, to achieve a greater distance, to climb hills and ride against the wind more easily. In its size, weight, speed and the driving skills required, the e-bike is similar to the conventional bicycle. A power-assisted bicycle is the same as an e-bike. An e-bike is considered a power-assisted bicycle as long as it meets all the requirements of the Motor Vehicle Safety Act.

Traveling by E-bike

Power-assisted bicycles will be able to travel anywhere a bicycle travel. They will be permitted on trails and paths where municipal by-laws permit bicycles. Power-assisted bicycles, like bicycles, are not allowed on controlled-access highways such as the 400 series highways, the Queen Elizabeth Way, the Queensway in Ottawa or the Kitchener-Waterloo Expressway, or on municipal roads, including sidewalks where bicycles are banned under municipal by-laws.

Who Can Ride an E-bike

Anyone who is 16 years of age or older and wears an approved bicycle helmet at all times while operating an e-bike can ride one.

Specific Riding Requirements

Power-assisted bicycles are treated as bicycles. This means:

- No driver's license is required
- No written test is required
- No vehicle registration or license plate is required
- No motor vehicle liability insurance is required
- Operators must be 16 years of age and older
- All persons are required to wear an approved bicycle helmet
- Only electric bicycles that conform to the federal Motor Vehicle Safety Act regulations and are labeled as a "power-assisted bicycle" are eligible for the pilot program

Equipment

A power-assisted bicycle (e-bike):

- Has steering handlebars and is equipped with pedals
- Is designed to be propelled primarily by muscular power and to travel on not more than three wheels
- Has a motor that has a power output rating of 500W or less. The motor is electric and is incapable of propelling the cycle at speed of 32km/h or greater on level ground, without pedaling.
- It must bear a label indicating that it is a "Power-Assisted Bicycle."

Safety Equipment

Power-assisted bicycles will require the same safety equipment as bicycles under the Highway Traffic Act:

- Proper lights
- Proper brakes
- Proper bell

Bicycle Helmets

Anyone operating an e-bike will be required to wear an approved bicycle helmet. There will be no age exemptions.

Fines and Penalties

All the set fines established for violating rules of the road and equipment standards that apply to bicyclists would apply to drivers of e-bikes. However, offences directly related to the pilot program (i.e.; riding an e-bike under the age of 16 or anyone riding an e-bike without a helmet) would be subject to the higher fines set for pilot projects, ranging from \$250 to \$2,500.

Drinking and Driving

Drinking and driving a motor vehicle is a Criminal Code offence and charges are laid under the Criminal Code of Canada. Under the Criminal Code, the definition of a “motor vehicle” would include an e-bike and anyone operating an e-bike intoxicated could be charged for impaired driving. If convicted, the offender would be subject to the Criminal Code penalties, including a fine or jail time, and a driving prohibition. However, under this pilot regulation, an e-bike would not be a motor vehicle under the Highway Traffic Act, so penalties for impaired driving under the Act would not apply.

Thank you for Choosing



GREEN YOUR LIFE



Any laws/regulations regarding “E-bikes” can be found on the Ministry of Transportation website:

www.mto.gov.on.ca

If you have further questions, please contact us at:

438 Spadina Avenue, Toronto ON

Toll Free: 1 888 510 3666 Tel: (416) 792-3227 www.emmo.ca

Email: info@emmo.ca